

PENTWATER TOWNSHIP BOARD

AGENDA PACKET

REGULAR BOARD MEETING

May 13, 2026 – 6:00 PM

Lynne Cavazos, Supervisor
Heather A. Douglas, Treasurer
Maureen H Murphy, Clerk

Mike Flynn, Trustee
Dean Holub, Trustee

PENTWATER TOWNSHIP BOARD MEETING
Regular Meeting

May 13, 2026 at 6:00 p.m.
Pentwater Township Hall
500 N. Hancock Street, Pentwater, MI 49449

Join Zoom Meeting
<https://us02web.zoom.us/j/86141326636?pwd=S2h88Zt71MqBl1j9ucIUvSHUgB1PSU.1>
Meeting ID: 861 4132 6636
Passcode: 446835
Dial by your location
+1 312 626 6799 US (Chicago)

AGENDA

- 1.** Call to Order/Pledge
- 2.** Roll Call
- 3.** Consent Agenda – Review & Action
 - a. Minutes of April 8, 2026
 - b. Correspondence: Michigan Public Policy Survey Results - 2025
 - c. Monthly Budget Reports for General Fund, Cemetery and Fire Department
 - d. Payment of Bills
(Consent Agenda contains all routine items of business on which no disagreement or debate is anticipated. Upon the request of any board member, an item shall be removed from the consent agenda and placed on the regular agenda under New Business)
- 4.** Meeting Agenda - Review & Action
- 5.** Public Comment on Agenda Items (Three (3) minutes maximum)
- 6.** Supervisor's Report
- 7.** Clerks' Report
- 8.** Treasurer's Report
- 9.** Library Board Information
- 10.** Fire Department Agendas & Minutes
- 11.** Recreation Report
- 12.** Reports
 - a. Zoning Administrator
 - b. Assessor
 - c. Cemetery Sexton
 - d. Transfer Station

13. Unfinished Business

a. Review & Action: Approval of New Contract with Pentwater Public Schools for Joint Recreation Program

b. Review & Action: Approval of Invoice for \$7,500 for Township contribution to 2025/2026 Park & Recreation Program.

14. New Business

a. Review & Action: Resolution for approval for COVE to use Business 31 for COVE Beach Walk/Run on August 1, 2026.

b. Review & Action: Approval of Park Place Agreement for Township Residents and Payment of Invoice of \$7,500.

c. Review & Action: Approval of Request from Pentwater Township Fire Department to sell Engine #341.

d. Review & Discussion: Site Accessibility Evaluation of Pentwater Township Hall by the Disability Network of West Michigan.

e. Review & Action: Approval of updated Purchase & Procurement Policy for Pentwater Township.

f. Review & Action: Replacement of split-rail fencing at Pentwater Township Cemetery – Review and Approval of Bid.

g. Review & Action: Approval of Request to Clean & Televise Township North Gravity Sewer System.

h. Review & Action: Approval of Request to Smoke Test the Township North Gravity Sewer System .

15. Public Comments (Three - 3 minutes maximum)

16. Other Items from Board Members

17. Adjournment

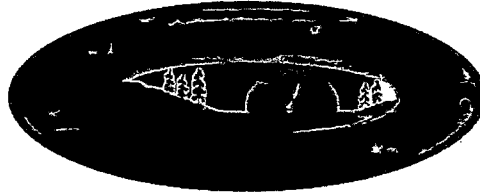

A General Law Township

Pentwater Township Regular Board Meeting

Consent Agenda Items

May 13, 2026

- Prior Meeting Minutes:
 - Township Regular Board Meeting – April 8, 2026
- Correspondence: Center for Local, State and Urban Policy
- Financial Reports for Period 4/01/26 thru 4/30/26
 - Claims/Bills as follows:
 - Township: \$11,629
 - Road: \$513
 - Cemetery: \$16,167 (Includes purchase of replacement pickup truck)
 - Sewer: \$17,006
 - Fire: \$150,979 (Includes final payment on ladder truck)
 - Payroll as follows:
 - Township/Cem/Sewer: \$47,313
 - Fire: \$39,904 (Bi-annual payout)

Pentwater Township Board Meeting Summary - 2026-04-08

Pentwater Township Board Meeting – April 8, 2026 Summary

Meeting Title: Pentwater Township Board Meeting

Date: April 8, 2026

Location: Pentwater Township Hall, MI

Timezone: America/New York

Board Member Participants: Lynne Cavazos (Supervisor), Maureen Murphy, Heather Douglas, Dean Holub, Mike Flynn

Other Staff Present: Keith Edwards, Glenn Beavis

Non-Staff Audience Present: Tom Roose, Veronica Parker, Chris Karaptian

Present via Zoom: Ted Cuchna

Executive Summary

The April 8, 2026 Pentwater Township Board meeting covered a wide range of township operations, infrastructure, and administrative updates. Major discussions included recycling and waste management improvements, sewer system upgrades and rate adjustments, accessibility compliance, cemetery operations, recreation program funding, road maintenance priorities, and audit contracts. The board approved several resolutions, including a sewer rate increase for Township South, adoption of a new sewer ordinance, and authorization for various operational contracts.

Key actions focused on improving township infrastructure, ensuring ADA compliance, supporting community recreation, and maintaining fiscal responsibility through multi-year audit planning.

Purpose of Meeting

Regular monthly board meeting to review township operations, approve financial and infrastructure actions, and address public comments.

Key Topics Discussed

1. Supervisor's Report

- Update on the five-county **Material Management Committee** focusing on recycling, waste, and composting infrastructure.
- **Transfer Station and Recycling Center** reopened under new contractor American Classic; emphasis on clean recyclable materials.
- **Disability Network Assessment** findings distributed; board to prioritize ADA compliance improvements.
- **Dock Accessibility Project:** Plans to add wheelchair-accessible features and safety bumpers.
- **Library Millage:** Supervisor appointed to committee to assist with upcoming millage planning.

2. Clerk's Report

- **Cemetery:** Opened April 1; five internments scheduled; new flags ordered; fee schedule updates forthcoming.
- **Truck Purchase:** Seeking a four-wheel-drive half-ton truck under \$20,000.
- **Cemetery Tours:** Determined not permissible under township ordinance.
- **Franchise Agreements:** Updates underway.
- **Election Prep:** No May election; primary August 4; general November 3.
- **Budget:** FY 26–27 budget adopted; payroll and tax reporting completed.
- **Recreation Program Funding:** Clerk's research confirmed shared funding between township and school is appropriate.

3. Treasurer's Report

- Tax settlement nearly complete; awaiting county confirmation.
- Upcoming training for MICPT certification.

4. Zoning and Sewer System Updates (Keith)

- **Sewer Rate Increase:** Approved 10% increase for Township South (from \$278.96 to \$306.86 per quarter) due to higher maintenance costs.

- **New Sewer Ordinance:** Adopted to align with village requirements and state law.
- **Inflow & Infiltration (I&I) Program:** Board approved pilot inspection program for Township North to identify illegal sump pump and drain connections.
- **Short-Term Rentals:** Discussion on regulating or surcharging rentals due to sewer capacity concerns; further legal review planned.

5. New Business

- **Lawn Care Contract:** Renewed with Brian's Lawn Care; \$46 per mowing plus \$20 monthly fuel surcharge.
- **Fishing Dock Repair:** Approved collaboration with Artisan Center to rebuild deteriorated dock boxes.
- **Recreation Program Invoice:** Adjusted payment to \$7,500 (from \$9,500) due to director's early departure.
- **Friends of the Transfer Station:** New volunteer group approved to assist with recycling education and monitoring.
- **Free Disposal Day:** Set for **August 22, 2026**, following the household hazardous waste day; winter schedule continues with monthly openings.
- **Training:** Treasurer approved to attend MMTA Advanced Institute (May 11–13, 2026).
- **MTA Governance Principles:** Board ratified updated principles and will display signed copy.
- **Summer Intern:** Approved hiring of CMU student for 9 weeks at \$18/hour to assist with GIS and planning projects.
- **Road Projects:** Approved **Ottawattamie Road** improvement (\$132,817); other projects deferred pending budget review.
- **Auditor Contracts:** Renewed partnership with Gabridge & Co. for FY 25–26 (\$9,250) and approved a 5-year engagement through 2030 with modest annual increases.

6. Public Comments

- Ted Kushner raised questions about sewer capacity, recycling volunteer incentives, and free day volume management.
- Discussion on potential development near the boathouse and accessibility improvements at Longbridge.
- No major objections: community support for recycling and infrastructure improvements noted.

7. Board Member Comments

- Clerk proposed digitizing invoices and payroll records; board agreed.
- Discussion on fire hydrant placement and potential sale of unused fire truck.
- Reminder to review ADA assessment for next meeting.

Major Decisions or Agreements

- **Approved:** 10% sewer rate increase for Township South.
- **Adopted:** New sanitary sewer ordinance (No. 2602).
- **Authorized:** Pilot I&I inspection program for Township North.
- **Approved:** Lawn care, dock repair, recreation payment adjustment, and volunteer recycling program.
- **Set:** August 22, 2026 as Free Disposal Day.
- **Approved:** Hiring of planning intern and Ottawattamie Road project.
- **Ratified:** MTA governance principles and 5-year auditor agreement.

Action Items and Owners

Action	Owner	Due
Meet with Road Commission engineers on Ottawattamie project	Maureen, Dean	Before construction
Develop pilot I&I inspection plan	Keith	Next meeting
Review ADA assessment priorities	All board members	May meeting
Post Free Day and recycling schedule online	Heather	Immediate
Coordinate Artisan Center dock rebuild	Mike	May 2026
Finalize 5-year audit contract	Mo	After board approval

Next Steps / Follow-Up

- Review ADA compliance report and prioritize improvements.
- Continue planning for recreation program transition to school oversight.
- Begin I&I pilot and evaluate sewer capacity management.
- Monitor recycling center operations and volunteer program effectiveness.
- Prepare for August Free Disposal Day logistics.

Source Note: Summary based on the April 8, 2026 Pentwater Township Board meeting transcript and related discussions. Additional township records may provide further context.

Motions Made During Meeting of 8 April 2026:

Consent Agenda:

Motion by Douglas, seconded by Murphy to accept the Consent Agenda as presented.

AYES: Cavazos, Murphy, Douglas, Holub, Flynn

NAYS: None

Motion: Carries

ACTION Needed: None

Meeting Agenda:

Motion by Holub, seconded by Flynn to accept the revised agenda as proposed

AYES: Cavazos, Murphy, Douglas, Holub, Flynn

NAYS: None

Motion: Carries

ACTION Needed: None

New Business:

(a) Review & Action: Resolution 2026-08 - Township South Sanitary Sewer System Rates – Proposed Quarterly Rate Increase – Resolution 2026-08

Motion by Douglas, seconded by Holub to approve Resolution 2026-08 for the proposed quarterly rate increase for Township South Sanitary Sewer System

AYES: Cavazos, Murphy, Douglas, Holub, Flynn

NAYS: None

Motion: Carries

ACTION Needed: Edwards: User notification; Douglas: Update sewer rate for next retroactive billing cycle

(b) Review and Action: Proposed Ordinance to Regulate use of Public and Private Sanitary Sewer.

Motion by Douglas, seconded by Murphy to approve Ordinance 26-02 to regulate use of public and private sanitary sewer system.

AYES: Cavazos, Murphy, Douglas, Holub, Flynn

NAYS: None

Motion: Carries

ACTION Needed: Prepare Notice of Adoption Summary, publish in Echo newspaper & request affidavit of publication to be sent to Township for our records

(c) Policy Discussion – Township Sanitary Sewer Capacity Concerns Regarding Use, Capacity, and Infiltration (I & I)

ACTION Needed: Keith: Design pilot program for Township North Sewer System. Investigate legality of imposing a premium fee on short term rental properties to offset township costs for usage overages. (Short term rental ordinance may be another option)

(d) Review & Action: Approval of Contract for Ryan's Lawn Care – Spring & Summer 2026

Motion by Holub, seconded by Flynn to approve 2026 contract with Ryan's Lawn Care

AYES: Cavazos, Murphy, Douglas, Holub, Flynn

NAYS: None

Motion: Carries

ACTION Needed: Murphy initiate contract with Ryan's Lawn Care

(e) Review & Action: Longbridge Fishing Deck Wooden Box Repairs

Motion by Cavazos, seconded by Murphy to make plans for repair of fishing dock wooden box.

AYES: Cavazos, Murphy, Douglas, Holub, Flynn

NAYS: None

Motion: Carries

ACTION Needed: Flynn determine box conditions, obtain dimensions & advise Cavazos; Cavazos obtain quote from Artisan Center for repair

(f) Review & Action: 2025-2026 Recreation Program Agreement

Motion by Douglas, seconded by Holub to submit payment to Pentwater Village in the amount of \$7,500 (less than was invoiced) for 2025-2026 Recreation Program

AYES: Cavazos, Murphy, Douglas, Holub, Flynn

NAYS: None

Motion: Carries

ACTION Needed: Murphy submit invoice payment of \$7,500. (Full invoice amount not approved)

(g) Review & Action: Discuss – Creation of a "Friends of the Pentwater Township Transfer Station & Recycling Center"

Motion by Douglas, seconded by Cavazos to approve creation of a "Friends of Pentwater Township Transfer Station & Recycling Center"

AYES: Cavazos, Murphy, Douglas, Holub, Flynn

NAYS: None

Motion: Carries

ACTION Needed: Holub to draft invitational notice for Douglas to post on the community website

From the Spring 2025 Michigan Public Policy Survey

Michigan local governments struggle to find residents willing to run for office or serve on boards



Center for Local, State, and Urban Policy

M | Gerald R. Ford School of Public Policy

1 Local leaders report there are not enough residents running for office or serving on appointed boards

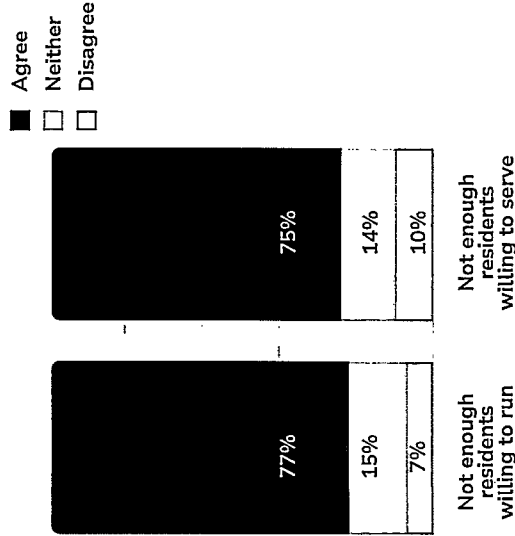

2 Challenges such as finding young people to serve, residents not having enough time, and potential harassment vary across rural and urban jurisdictions

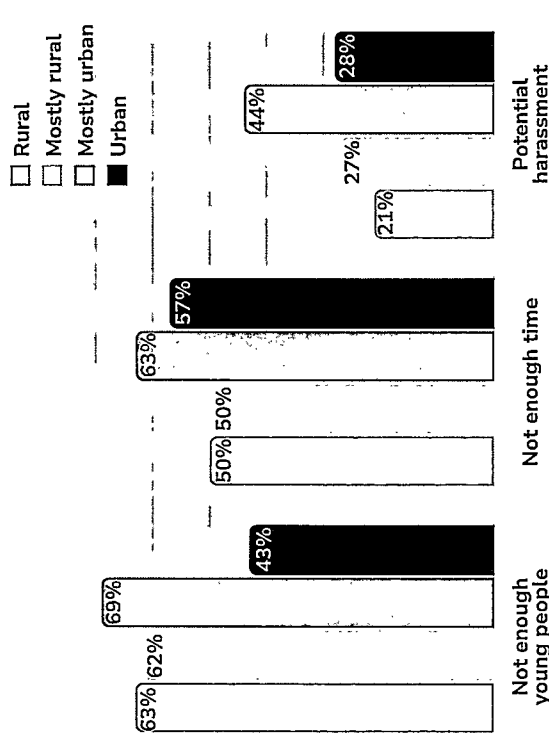

3 Word-of-mouth reported as most effective method for encouraging residents to run or serve

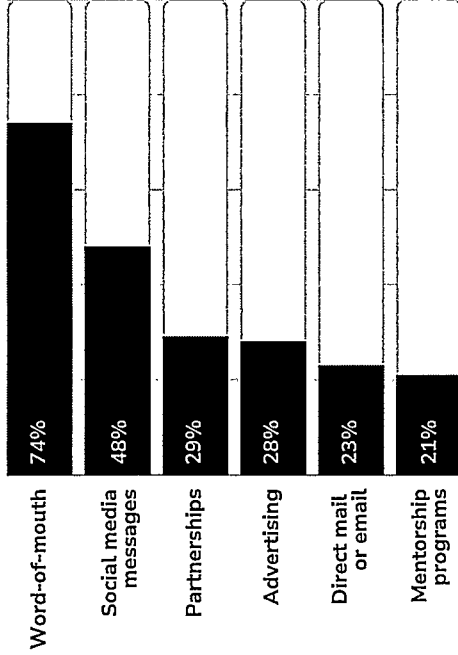

% who agree methods are effective

Website: closup.umich.edu

email: CLOSUP@UMICH.EDU

Source: 2025 Michigan Public Policy Survey

CORRESPONDENCE



MPPS Policy Brief

Many Michigan local governments struggle to find residents willing to run for office or serve on boards

By Natalie Fitzpatrick, Debra Horner, and Stephanie Leiser

The Spring 2025 wave of the Michigan Public Policy Survey (MPPS) asked local government officials a wide range of questions about resident engagement in their communities.¹ Across the state, Michigan local leaders report steep declines in engagement over more than a decade, despite increased outreach efforts to their residents.

One significant area of concern is resident representation on local elected and appointed boards. As shown in *Figure 1a*, local leaders from more than three-quarters of Michigan jurisdictions statewide agree that not enough residents are willing to run for local elected office in their jurisdiction (77%), and that candidacies are often uncontested (75%). Beyond elected offices, a similar proportion of local leaders also say not enough residents are willing to serve on the jurisdiction's appointed boards or committees (75%), such as planning commissions, zoning boards of appeals, downtown development authorities, or advisory boards on parks and recreation. In addition, 68% report that their jurisdiction struggles to find residents with the necessary skills or subject matter expertise for certain appointed boards.

Figure 1a

Percentage of local officials who agree or disagree with concerns over residents running for office or serving on boards

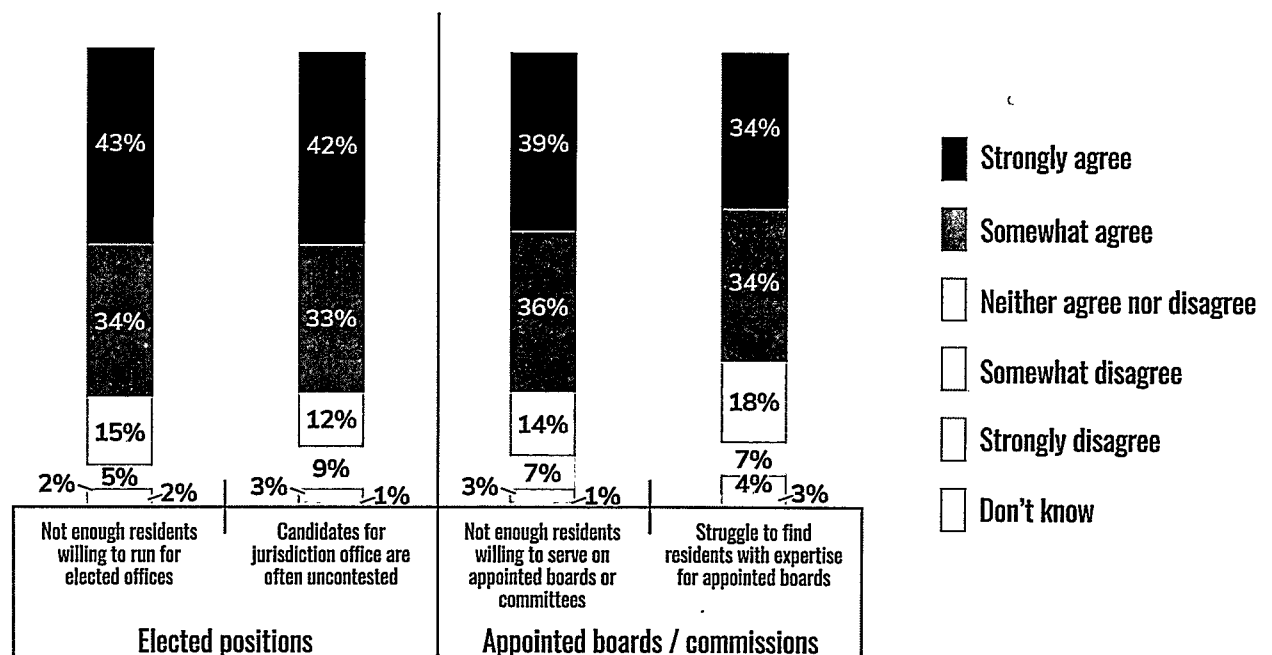

All four of these challenges are widely found in every jurisdiction type, from counties to townships. However, local leaders from the state’s smaller and more rural jurisdictions, particularly villages and townships, are more likely to express strong concerns about them. For example, while 19% of county leaders and 34% of city leaders strongly agree that not enough residents are willing to run for local elected office, that percentage rises to a majority of villages (51%) and nearly half of townships (45%) statewide (see *Figure 1b*). Similarly, approximately a quarter of local leaders from mostly urban and urban communities express significant concerns with resident recruitment to run for office or serve on appointed boards, compared with around twice that percentage in Michigan’s rural communities (see *Figure 1c*).

Figure 1b
Percentage of local officials who “somewhat” or “strongly” agree with not enough residents running for office or serving on boards, by jurisdiction type

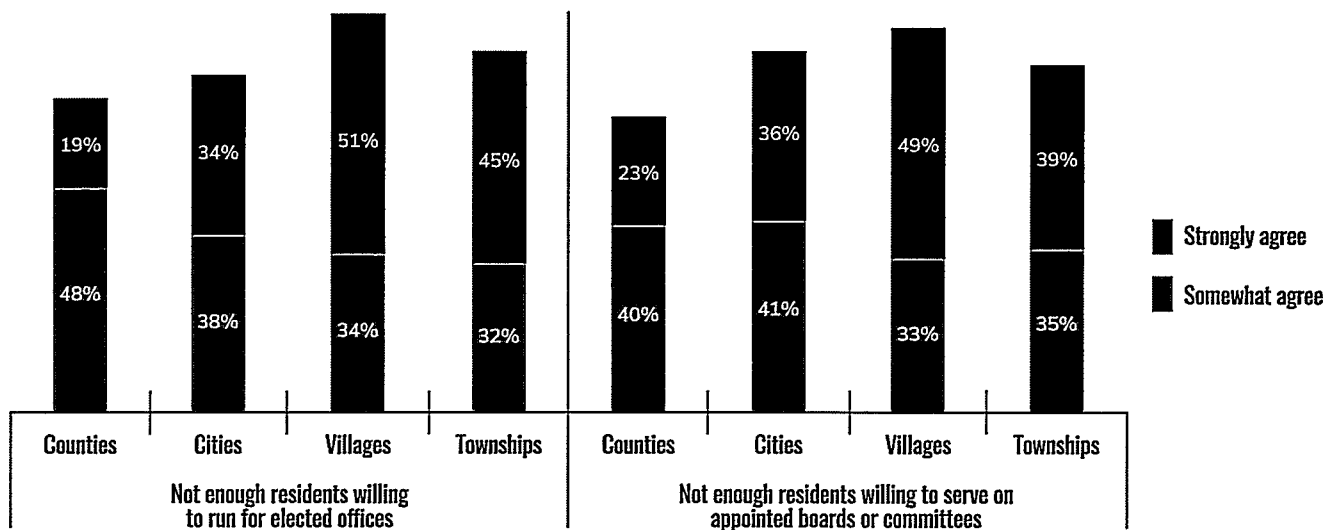
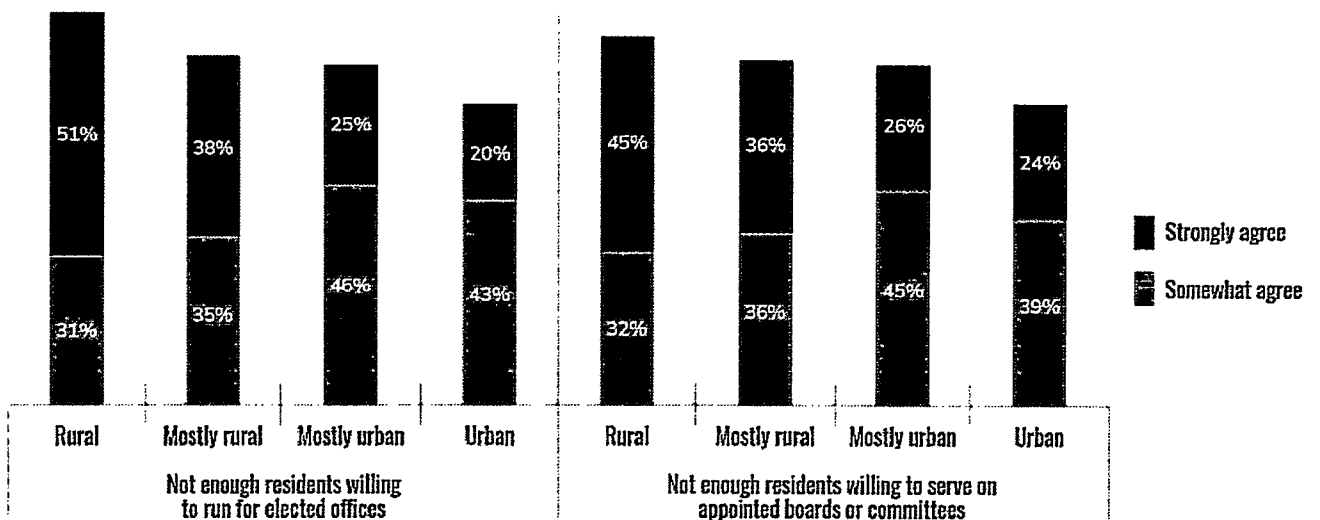

Figure 1c
Percentage of local officials who “somewhat” or “strongly” agree with not enough residents running for office or serving on boards, by rural-urban self-assessment





Local leaders worry about finding young people to run or serve, believe residents don't have time

When asked about specific challenges related to finding residents to run for office or serve on appointed boards, 61% of local officials statewide say it's difficult for their jurisdiction to find young people to run or serve, and 34% say they can't find new people in general (see Figure 2). About half feel their jurisdiction's residents don't have time to run or serve, and 43% believe their residents feel unsure that they have enough knowledge or expertise to serve on boards. One quarter believe their residents are deterred from running because of potential harassment, which reflects [earlier MPPS findings from 2022](#) that 47% of local officials say they personally experienced online or in-person harassment while serving in their role in local government.²

As shown in *Appendix A*, local leaders who characterize their community as “mostly urban” are more likely to cite problems in several areas compared with officials from either rural or urban places, including residents not having time to run or serve (63%), resident concerns about harassment (44%), difficulty finding new people to run or serve (44%), and residents caring more about state or national politics (38%).

Figure 2
Percentage identifying specific problems related to finding residents to run for office and/or serve on appointed boards

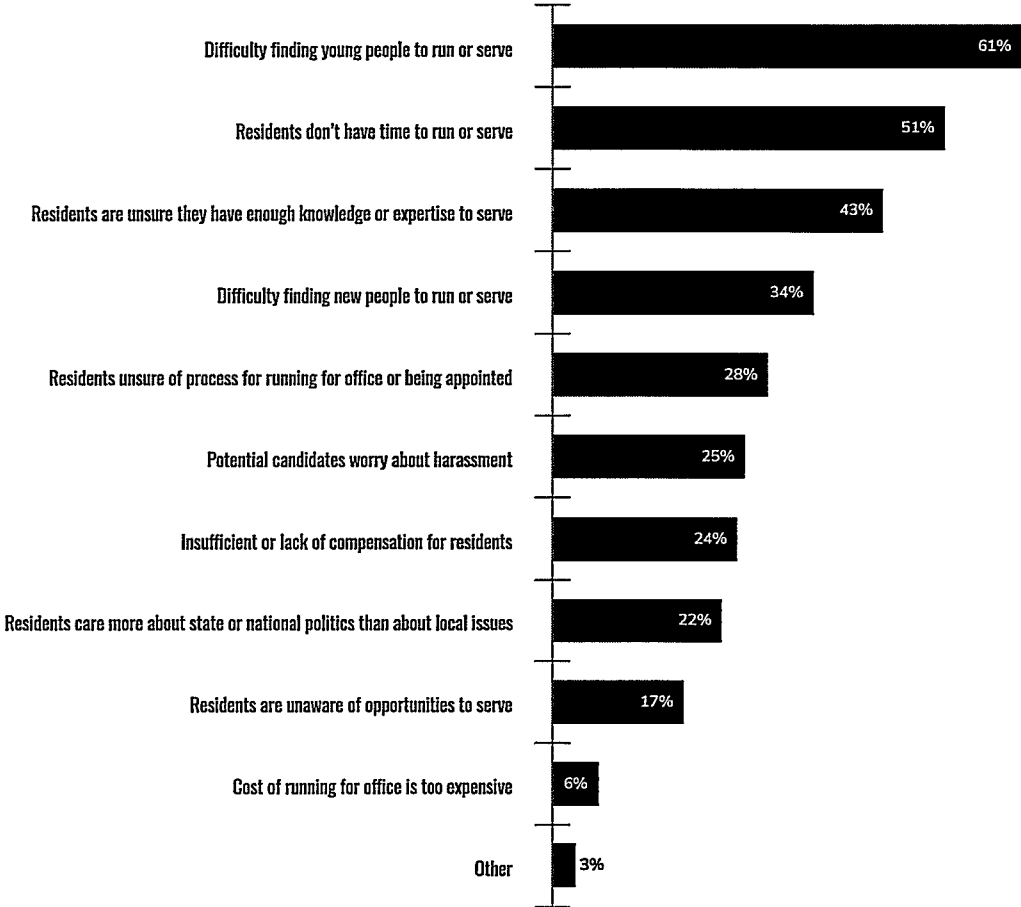

Word-of-mouth seen as the most effective approach to overcoming recruitment problems

The MPPS also asked local officials what kinds of outreach methods are, or could be, most effective for encouraging residents to run for office or serve on appointed boards. By far the most commonly cited outreach method is simple word-of-mouth, which 74% of local leaders endorse (see *Figure 3*). Almost half of officials (48%) say social media is, or could be, effective in resident recruitment, reflecting broader trends in increased use of social media for resident outreach and engagement. Currently, over half (51%) of local governments say they use social media accounts for some types of resident outreach, compared with just 18% who were doing so in 2012.³ Local leaders in urban (70%) and mostly urban (68%) communities are especially likely to recommend social media as a strategy to recruit residents (see *Appendix B*).

Other than for social media, there are few significant differences among officials along the rural-urban spectrum on what they believe could be effective in boosting resident recruitment.

Figure 3

Percentage identifying outreach methods most effective in their jurisdiction for encouraging residents to run for office or serve on appointed boards

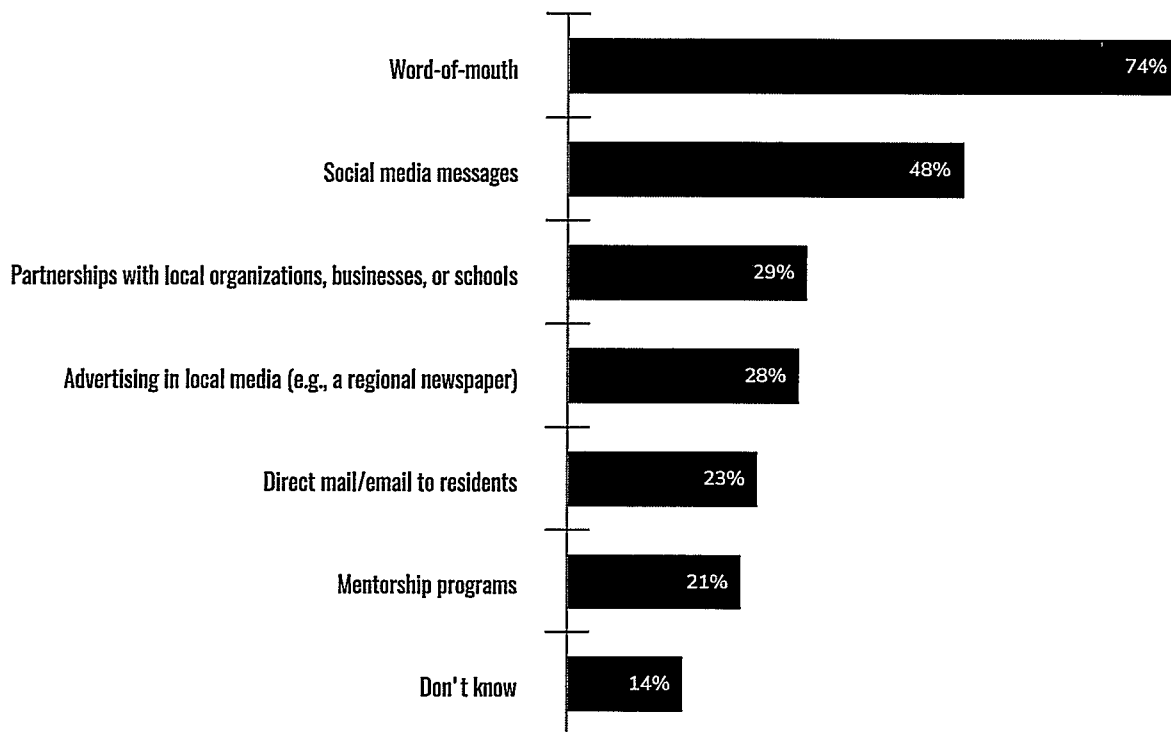



The MPPS also asked local government officials to describe the ways in which things were either going well or going poorly with their resident engagement, and many included comments about their recruitment of residents to run for office or serve on appointed boards. These comments cite many of the same problems noted in the results above, particularly the cost of running for office and the lack of compensation for serving and volunteering time.

Voices Across Michigan

Quotes from local leaders about successes or concerns with resident recruitment to run or serve:

"We need more time and more resources. Board positions are publicly understood to be part-time, 10-15 hours per week. In reality, it is a full-time job paid at only \$21,000/year. So, no one will run, but the public expects the results of a full-time professional in elected positions."

"All our rural townships have the same problems recruiting new or young people to get involved. It's mostly the rate of pay."

"One of the most significant barriers we've encountered in encouraging younger participation is compensation. Many younger residents are balancing multiple jobs or family obligations, and unfortunately, our township simply doesn't have the budget to offer competitive wages for committee work or part-time township positions. State and federal funding cuts have only made that more difficult."

"As Supervisor, if I have a specific need on a Board or Commission for a candidate with expertise in a particular area (wastewater, assessing, public safety, etc.) I have formed an advisory board (of community leaders) to seek out a list of candidates to ensure that no one person can hand-pick who they want to serve. It allows for the best person for the position to fill it."

"If we can predict a vacancy, we discuss with appropriate individuals the need for their participation, and it is generally well received."

"I think it is an overall problem with residents not having enough time, who have young families and are already juggling other duties."

"The divisiveness in the community keeps good people from running or offering to serve on boards, as they do not want in be harassed."

"[Running for local office] is largely a closed-door society. If you do not have an in, you likely will not be viewed as a credible candidate... It's too tough to break in within a large town without large money and a large cast of supportive politicians."

"More engaged residents could see that serving is a noble cause. It is very rewarding even in today's fragmented climate."

Appendix A

Percentage identifying specific problems related to finding residents to run for office and/or serve on appointed boards, by rural-urban self-identification

	Rural	Mostly Rural	Mostly Urban	Urban	Total
Residents are unaware of opportunities to serve	14%	20%	20%	25%	17%
Residents unsure of process/ procedures for running for office or being appointed	27%	34%	26%	23%	28%
Residents don't have time to run or serve	50%	50%	63%	57%	51%
Residents are unsure they have enough knowledge/expertise to serve	43%	44%	42%	41%	43%
Insufficient or lack of compensation for residents to run or serve	27%	22%	20%	24%	24%
Cost of running for office is too expensive	3%	5%	14%	16%	6%
Potential candidates worry about harassment	21%	27%	44%	28%	25%
Residents care more about state or national politics than about local issues	19%	24%	38%	28%	23%
Difficulty finding new people to run or serve	32%	36%	44%	28%	34%
Difficulty finding young people to run or serve	63%	62%	69%	43%	62%
Jurisdiction faces other problems in finding residents to run or serve	4%	2%	2%	5%	3%



Appendix B

Percentage identifying outreach methods most effective in their jurisdiction for encouraging residents to run for office or serve on appointed boards, by rural-urban self-identification

	Rural	Mostly Rural	Mostly Urban	Urban	Total
Word-of-mouth could encourage residents to run or serve	72%	78%	83%	75%	74%
Social media messages could encourage residents to run or serve	41%	52%	68%	70%	48%
Advertising in local media could encourage residents to run or serve	26%	29%	33%	25%	27%
Direct mail/email to residents could encourage residents to run or serve	21%	24%	29%	27%	23%
Partnership w/ local orgs/bus/school could encourage residents to run or	22%	36%	43%	41%	29%
Mentorship programs could encourage residents to run or serve	18%	23%	31%	34%	21%

Notes

1. Fitzpatrick, N., Horner, D., and Leiser, S. (October 2025). *Michigan local leaders report alarming declines in resident engagement*. Ann Arbor, MI: Center for Local, State, and Urban Policy at the Gerald R. Ford School of Public Policy, University of Michigan. Retrieved from <https://closup.umich.edu/michigan-public-policy-survey/137/mpps-michigan-local-leaders-report-alarming-declines-resident-engagement>
2. Fitzpatrick, N., Horner, D., and Ivacko, T. (September 2022). *Statewide survey finds a majority of Michigan local governments experiencing harassment or other abuse*. Ann Arbor, MI: Center for Local, State, and Urban Policy at the Gerald R. Ford School of Public Policy, University of Michigan. Retrieved from <https://closup.umich.edu/michigan-public-policy-survey/103/mpps-policy-brief-statewide-survey-finds-majority-michigan-local-governments-experiencing-harassment-abuse>
3. Fitzpatrick, N., Horner, D., and Leiser, S. (October 2025).

Survey Background and Methodology

The Michigan Public Policy Survey (MPPS) is an ongoing census survey of all 1,856 general-purpose local governments in Michigan conducted since 2009 by the Center for Local, State, and Urban Policy (CLOSUP) at the University of Michigan's Gerald R Ford School of Public Policy. The program is a partnership with Michigan's local government associations. The Spring 2025 wave was conducted April 7 – June 12, 2025. Respondents include county administrators, board chairs, and clerks; city mayors, managers, and clerks; village presidents, managers, and clerks; and township supervisors, managers, and clerks from 1,328 jurisdictions across the state, resulting in a 72% response rate by unit. More information is available at <https://closup.umich.edu/michigan-public-policy-survey/mpps-2025-spring>

See CLOSUP's website for the full question text on the survey questionnaire. Detailed tables of the data in this report, including breakdowns by various community characteristics, are available at <http://mpps.umich.edu>.

The survey responses presented here are those of local Michigan officials, while further analysis represents the views of the authors. Neither necessarily reflects the views of the University of Michigan, or of other partners in the MPPS.

CASH SUMMARY BY ACCOUNT FOR PENTWATER TOWNSHIP
 FROM 04/01/2026 TO 04/30/2026
 FUND: 101 204 206 209 592
 CASH AND INVESTMENT ACCOUNTS

Fund Account	Description	Beginning Balance 04/01/2026	Total Debits	Total Credits	Ending Balance 04/30/2026
Fund 101	GENERAL FUND				
004.000	PETTY CASH	151.00	0.00	0.00	151.00
006.000	POOLED CASH	444,820.19	169,466.05	51,155.08	563,131.16
017.000	MI CLASS - GENERAL FUND	17,576.60	0.00	0.00	17,576.60
017.003	MICLASS HART-PTW NON-MOTORIZED TR	26,731.47	0.00	0.00	26,731.47
017.004	CFCU FUND BALANCE POLICY CD	133,636.71	0.00	0.00	133,636.71
017.005	CONSUMERS CREDIT UNION PRIM BUS S	27.78	0.00	0.00	27.78
	GENERAL FUND	<u>622,943.75</u>	<u>169,466.05</u>	<u>51,155.08</u>	<u>741,254.72</u>
Fund 204	ROAD FUND				
001.001	MI CLASS - ROAD FUND	63,607.91	0.00	0.00	63,607.91
006.000	POOLED CASH	34,805.27	55,692.45	1,370.25	89,127.47
017.000	MC EDGE - ROAD FUND	(115.42)	0.00	0.00	(115.42)
	ROAD FUND	<u>98,297.76</u>	<u>55,692.45</u>	<u>1,370.25</u>	<u>152,619.96</u>
Fund 206	FIRE FUND				
001.000	CHECKING ACCT	248,450.20	165,850.74	47,434.53	366,866.41
001.001	MI CLASS - FD	257,272.01	0.00	0.00	257,272.01
	FIRE FUND	<u>505,722.21</u>	<u>165,850.74</u>	<u>47,434.53</u>	<u>624,138.42</u>
Fund 209	CEMETERY FUND				
001.001	MI CLASS - CEMETERY	341,337.77	0.00	0.00	341,337.77
006.000	POOLED CASH	72,878.68	39,174.96	15,734.13	96,319.51
	CEMETERY FUND	<u>414,216.45</u>	<u>39,174.96</u>	<u>15,734.13</u>	<u>437,657.28</u>
Fund 592	SEWER FUND				
006.000	POOLED CASH	88,623.57	17,807.52	6,326.39	100,104.70
	TOTAL - ALL FUNDS	<u>1,729,803.74</u>	<u>447,991.72</u>	<u>122,020.38</u>	<u>2,055,775.08</u>

Fund 101 GENERAL FUND

GL Number	Description	Current Year Beg. Balance	Balance
*** Assets ***			
101-000-004.000	PETTY CASH	151.00	151.00
101-000-006.000	POOLED CASH	444,820.19	563,131.16
101-000-017.000	MI CLASS - GENERAL FUND	17,576.60	17,576.60
101-000-017.003	MICLASS HART-PTW NON-MOTORIZED TRAIL	26,731.47	26,731.47
101-000-017.004	CFCU FUND BALANCE POLICY CD	133,636.71	133,636.71
101-000-017.005	CONSUMERS CREDIT UNION PRIM BUS SHARE	27.78	27.78
101-000-072.000	DUE FROM COUNTY	18,439.65	18,439.65
101-000-078.000	DUE FROM STATE	13,529.00	13,529.00
101-000-084.206	DUE FROM FIRE	(17,719.00)	(17,719.00)
101-000-193.001	INTREST ON LONG TERM ADVANCE	2,022.57	2,022.57
Total Assets		639,215.97	757,526.94
*** Liabilities ***			
101-000-202.000	ACCOUNTS PAYABLE	9,461.88	5,273.32
101-000-214.206	DUE TO FIRE DEPT	(17,719.00)	(17,719.00)
101-000-258.001	P/R LIABILITIES - FWT	(29.20)	(29.20)
101-000-258.002	P/R LIABILITIES - SS WH	(10.44)	(10.44)
101-000-258.003	P/R LIABILITIES - MED WH	(2.44)	(2.44)
101-000-258.004	P/R LIABILITIES - SWT	(45.69)	1,158.66
Total Liabilities		(8,344.89)	(11,329.10)
*** Fund Balance ***			
101-000-390.000	FUND BALANCE	677,061.66	677,061.66
Total Fund Balance		677,061.66	677,061.66
Beginning Fund Balance - 25-26			677,061.66
Net of Revenues VS Expenditures - 25-26			(29,500.80)
*25-26 End FB/26-27 Beg FB		647,560.86	
Net of Revenues VS Expenditures - Current Year			121,295.18
Ending Fund Balance			768,856.04
Total Liabilities And Fund Balance			757,526.94

* Year Not Closed

Fund 204 ROAD FUND

GL Number	Description	Current Year Beg. Balance	Balance
*** Assets ***			
204-000-001.001	MI CLASS - ROAD FUND	63,607.91	63,607.91
204-000-006.000	POOLED CASH	34,805.27	89,127.47
204-000-017.000	MC EDGE - ROAD FUND	(115.42)	(115.42)
204-000-072.000	DUE FROM COUNTY	6,175.13	6,175.13
Total Assets		104,472.89	158,795.09
*** Liabilities ***			
204-000-202.000	ACCOUNTS PAYABLE	1,352.00	495.00
Total Liabilities		1,352.00	495.00
*** Fund Balance ***			
204-000-390.000	FUND BALANCE	258,603.70	258,603.70
Total Fund Balance		258,603.70	258,603.70
Beginning Fund Balance - 25-26			258,603.70
Net of Revenues VS Expenditures - 25-26			(155,482.81)
*25-26 End FB/26-27 Beg FB		103,120.89	
Net of Revenues VS Expenditures - Current Year			55,179.20
Ending Fund Balance			158,300.09
Total Liabilities And Fund Balance			158,795.09

* Year Not Closed

Fund 209 CEMETERY FUND

GL Number	Description	Current Year Beg. Balance	Balance
*** Assets ***			
209-000-001.001	MI CLASS - CEMETERY	341,337.77	341,337.77
209-000-006.000	POOLED CASH	72,878.68	96,319.51
209-000-072.000	DUE FR COUNTY	4,143.75	4,143.75
Total Assets		418,360.20	441,801.03
*** Liabilities ***			
209-000-202.000	ACCOUNTS PAYABLE	927.04	4,998.19
209-000-258.004	P/R LIABILITIES - SWT	0.00	78.43
Total Liabilities		927.04	5,076.62
*** Fund Balance ***			
209-000-390.000	FUND BALANCE	431,785.57	431,785.57
Total Fund Balance		431,785.57	431,785.57
Beginning Fund Balance - 25-26			431,785.57
Net of Revenues VS Expenditures - 25-26			(14,352.41)
*25-26 End FB/26-27 Beg FB		417,433.16	
Net of Revenues VS Expenditures - Current Year			19,291.25
Ending Fund Balance			436,724.41
Total Liabilities And Fund Balance			441,801.03

* Year Not Closed

Fund 592 SEWER FUND

GL Number	Description	Current Year Beg. Balance	Balance
*** Assets ***			
592-000-006.000	POOLED CASH	88,623.57	100,104.70
592-000-033.000	UTILITY BILLS RECEIVABLE	4,597.78	27,343.26
Total Assets		93,221.35	127,447.96
*** Liabilities ***			
592-000-202.000	ACCOUNTS PAYABLE	5,050.57	16,606.84
Total Liabilities		5,050.57	16,606.84
*** Fund Balance ***			
592-000-390.000	FUND BALANCE	4,849.52	4,849.52
Total Fund Balance		4,849.52	4,849.52
Beginning Fund Balance - 25-26			4,849.52
Net of Revenues VS Expenditures - 25-26			83,321.26
*25-26 End FB/26-27 Beg FB		88,170.78	
Net of Revenues VS Expenditures - Current Year			22,670.34
Ending Fund Balance			110,841.12
Total Liabilities And Fund Balance			127,447.96

* Year Not Closed

Fund 206 FIRE FUND

GL Number	Description	Current Year Beg. Balance	Balance
*** Assets ***			
206-000-001.000	CHECKING ACCT	248,450.20	366,866.41
206-000-001.001	MI CLASS - FD	257,272.01	257,272.01
206-000-072.000	MFR DUE FROM CO	18,387.45	18,387.45
206-000-084.101	DUE FROM GF	133,851.73	133,851.73
206-000-140.000	CAP ASSETS	1,066,898.00	1,066,898.00
Total Assets		1,724,859.39	1,843,275.60
*** Liabilities ***			
206-000-202.000	ACCOUNTS PAYABLE	10,458.86	149,789.71
206-000-214.101	DUE TO GENERAL FUND	(17,719.00)	(17,719.00)
206-000-252.000	ACCURED INTEREST PAYABLE	716.25	716.25
206-000-258.002	ACC MEDICARE	51.38	51.38
206-000-258.003	ACC SWT	2.18	2.18
206-000-258.004	P/R LIABILITIES - SWT	(0.59)	1,072.16
206-000-301.000	LONG TERM DEBT	238,668.00	238,668.00
Total Liabilities		232,177.08	372,580.68
*** Fund Balance ***			
206-000-390.002	RET EARNINGS	1,397,298.27	1,397,298.27
Total Fund Balance		1,397,298.27	1,397,298.27
Beginning Fund Balance - 25-26			1,397,298.27
Net of Revenues VS Expenditures - 25-26			95,384.04
*25-26 End FB/26-27 Beg FB		1,492,682.31	
Net of Revenues VS Expenditures - Current Year			(21,987.39)
Ending Fund Balance			1,470,694.92
Total Liabilities And Fund Balance			1,843,275.60

* Year Not Closed

User: GLENN
 DB: PENTWATER TWP

GL NUMBER	DESCRIPTION	2026-27		2026-27		ACTIVITY FOR MONTH 04/30/26	AVAILABLE		% BGD	
		ORIGINAL BUDGET	AMENDED BUDGET	YTD BALANCE 04/30/2026	NORM (ABNORM)		NORM (ABNORM)	BALANCE		
Fund 101 - GENERAL FUND										
Revenues										
Dept 000										
101-000-400.000	FROM PREV YEAR END	16,058.00	16,058.00	0.00	0.00	0.00	16,058.00	0.00	0.00	
101-000-402.000	CURRENT REAL PROPERTY	363,211.00	363,211.00	133,617.04	133,617.04	133,617.04	229,593.96	36.79	36.79	
101-000-405.001	ADMIN FEE LAND BANK	0.00	0.00	1.63	1.63	1.63	(1.63)	100.00	100.00	
101-000-411.000	DELINQUENT REAL PROP TAX	19,116.00	19,116.00	0.00	0.00	0.00	19,116.00	0.00	0.00	
101-000-429.000	COMM FOREST TAX	34.00	34.00	0.00	0.00	0.00	34.00	0.00	0.00	
101-000-432.000	STATE PMT IN LIEU OF TAX (PILT)	3,900.00	3,900.00	0.00	0.00	0.00	3,900.00	0.00	0.00	
101-000-434.000	TRAILER PARK TAX	220.00	220.00	0.00	0.00	0.00	220.00	0.00	0.00	
101-000-442.000	HOMESTEAD DENIALS	800.00	800.00	0.00	0.00	0.00	800.00	0.00	0.00	
101-000-447.000	TAX ADMINISTRATION FEE	114,000.00	114,000.00	0.00	0.00	0.00	114,000.00	0.00	0.00	
101-000-447.001	DELINQUENT TAX ADMIN FEE	6,000.00	6,000.00	0.00	0.00	0.00	6,000.00	0.00	0.00	
101-000-449.000	SET REIMBURSEMENT	7,200.00	7,200.00	29,354.90	29,354.90	29,354.90	(22,154.90)	407.71	407.71	
101-000-477.000	FRANCHISE FEES (CHARTER COMM)	8,000.00	8,000.00	0.00	0.00	0.00	8,000.00	0.00	0.00	
101-000-479.000	ZONING PERMIT FEES	2,100.00	2,100.00	350.00	350.00	350.00	1,750.00	16.67	16.67	
101-000-481.000	PLANNING COMMISSION REVIEW FEES	1,500.00	1,500.00	0.00	0.00	0.00	1,500.00	0.00	0.00	
101-000-541.001	TSRC STATE GRANT	0.00	0.00	0.00	0.00	0.00	0.00	0.00	0.00	
101-000-549.000	ELECTION REIMBURSEMENT	0.00	0.00	0.00	0.00	0.00	0.00	0.00	0.00	
101-000-569.000	OTHER STATE GRANTS	3.00	3.00	0.00	0.00	0.00	3.00	0.00	0.00	
101-000-569.001	OTHER STATE GRANTS SBTE REIM OPERATI	260.00	260.00	0.00	0.00	0.00	260.00	0.00	0.00	
101-000-573.000	LOCAL COMMUNITY STABILIZATION SHARE	4,500.00	4,500.00	0.00	0.00	0.00	4,500.00	0.00	0.00	
101-000-574.000	CONSTITUTIONAL STATE SHARED REVENUE	81,166.00	81,166.00	0.00	0.00	0.00	81,166.00	0.00	0.00	
101-000-574.001	STATUTORY REVENUE SHARING TWP	100.00	100.00	0.00	0.00	0.00	100.00	0.00	0.00	
101-000-574.002	STATUTORY REVENUE SHARING WPP	269.00	269.00	0.00	0.00	0.00	269.00	0.00	0.00	
101-000-580.000	LOCAL UNIT GRANTS	0.00	0.00	0.00	0.00	0.00	0.00	0.00	0.00	
101-000-607.000	LAND DIV FEE	300.00	300.00	0.00	0.00	0.00	300.00	0.00	0.00	
101-000-607.002	ZBA FEES	800.00	800.00	0.00	0.00	0.00	800.00	0.00	0.00	
101-000-607.003	ZONING - TWP BOARD REVIEW FEES	500.00	500.00	0.00	0.00	0.00	500.00	0.00	0.00	
101-000-626.000	COPY FEES	0.00	0.00	0.00	0.00	0.00	0.00	0.00	0.00	
101-000-628.000	TRANSFER SITE FEES	20,000.00	20,000.00	2,097.00	2,097.00	2,097.00	17,903.00	10.49	10.49	
101-000-664.000	INTEREST INCOME	15,000.00	15,000.00	0.00	0.00	0.00	15,000.00	0.00	0.00	
101-000-670.000	INTEREST ON SEWER LT ADVANCE	2,750.00	2,750.00	0.00	0.00	0.00	2,750.00	0.00	0.00	
101-000-686.000	MISCELLANEOUS	1,000.00	1,000.00	3,944.00	3,944.00	3,944.00	(2,944.00)	394.40	394.40	
101-000-699.000	TRANSFER IN	0.00	0.00	0.00	0.00	0.00	0.00	0.00	0.00	
Total Dept 000		668,787.00	668,787.00	169,364.57	169,364.57	169,364.57	499,422.43	25.32	25.32	
TOTAL REVENUES										
Expenditures										
Dept 101 - TOWNSHIP BOARD										
101-101-702.000	SALARIES & WAGES	4,622.00	4,622.00	298.62	298.62	298.62	4,323.38	6.46	6.46	
101-101-705.000	EMPLOYER FICA CONTRIB	354.00	354.00	22.85	22.85	22.85	331.15	6.45	6.45	
101-101-995.000	TRANSFER OUT	0.00	0.00	0.00	0.00	0.00	0.00	0.00	0.00	
Total Dept 101 - TOWNSHIP BOARD		4,976.00	4,976.00	321.47	321.47	321.47	4,654.53	6.46	6.46	
Dept 171 - SUPERVISOR										
101-171-702.000	SALARIES & WAGES	39,602.00	39,602.00	4,529.38	4,529.38	4,529.38	35,072.62	11.44	11.44	
101-171-702.001	DEPUTY WAGES	3,000.00	3,000.00	306.30	306.30	306.30	2,693.70	10.21	10.21	
101-171-705.000	EMPLOYER FICA CONTRIB	4,000.00	4,000.00	369.92	369.92	369.92	3,630.08	9.25	9.25	
101-171-815.000	EDUCATION/TRAINING	1,500.00	1,500.00	0.00	0.00	0.00	1,500.00	0.00	0.00	
101-171-860.000	TRAVEL	700.00	700.00	0.00	0.00	0.00	700.00	0.00	0.00	

User: GLENN
 DB: PENTWATER TWP

GL NUMBER	DESCRIPTION	2026-27		YTD BALANCE 04/30/2026 NORM (ABNORM)	ACTIVITY FOR MONTH 04/30/26		AVAILABLE BALANCE NORM (ABNORM)	% BDCET USED
		ORIGINAL BUDGET	2026-27 AMENDED BUDGET		INCR (DECR)			
Fund 101 - GENERAL FUND								
Expenditures								
Total Dept 171 - SUPERVISOR		48,802.00	48,802.00	5,205.60	5,205.60		43,596.40	10.67
Dept 215 - CLERK								
101-215-702.000	SALARIES & WAGES	39,602.00	39,602.00	4,529.38	4,529.38		35,072.62	11.44
101-215-702.001	DEPUTY WAGES	29,738.00	29,738.00	3,862.04	3,862.04		25,875.96	12.99
101-215-705.000	EMPLOYER FICA CONTRIB	5,300.00	5,300.00	647.44	647.44		4,652.56	12.22
101-215-712.000	REC SECRETARY	700.00	700.00	72.12	72.12		627.88	10.30
101-215-815.000	EDUCATION/TRAINING	2,500.00	2,500.00	0.00	0.00		2,500.00	0.00
101-215-860.000	TRAVEL	3,500.00	3,500.00	0.00	0.00		3,500.00	0.00
Total Dept 215 - CLERK		81,340.00	81,340.00	9,110.98	9,110.98		72,229.02	11.20
Dept 247 - BOARD OF REVIEW								
101-247-702.000	SALARIES & WAGES	1,228.00	1,228.00	0.00	0.00		1,228.00	0.00
101-247-705.000	EMPLOYER FICA CONTRIB	94.00	94.00	0.00	0.00		94.00	0.00
101-247-815.000	EDUCATION/TRAINING	150.00	150.00	0.00	0.00		150.00	0.00
101-247-860.000	TRAVEL EXPENSES	100.00	100.00	0.00	0.00		100.00	0.00
101-247-900.000	PRINT/PUBLISH	100.00	100.00	0.00	0.00		100.00	0.00
101-247-955.000	MISCELLANEOUS	500.00	500.00	0.00	0.00		500.00	0.00
Total Dept 247 - BOARD OF REVIEW		2,172.00	2,172.00	0.00	0.00		2,172.00	0.00
Dept 253 - TREASURER								
101-253-702.000	SALARIES & WAGES	39,602.00	39,602.00	4,529.38	4,529.38		35,072.62	11.44
101-253-702.001	DEPUTY WAGES	13,748.00	13,748.00	769.81	769.81		12,978.19	5.60
101-253-705.000	EMPLOYER FICA CONTRIB	4,082.00	4,082.00	405.38	405.38		3,676.62	9.93
101-253-713.000	COLLEGE TUITION	1,000.00	1,000.00	0.00	0.00		1,000.00	0.00
101-253-802.000	PROF SERV SOFTW	4,250.00	4,250.00	24.37	24.37		4,225.63	0.57
101-253-815.000	EDUCATION/TRAINING	2,000.00	2,000.00	198.00	198.00		1,802.00	9.90
101-253-851.000	POSTAGE	5,800.00	5,800.00	78.00	78.00		5,722.00	1.34
101-253-860.000	TRAVEL	2,700.00	2,700.00	0.00	0.00		2,700.00	0.00
101-253-915.000	MEMBER/DUES	160.00	160.00	0.00	0.00		160.00	0.00
101-253-964.000	REFUNDS	0.00	0.00	0.00	0.00		0.00	0.00
Total Dept 253 - TREASURER		73,342.00	73,342.00	6,004.94	6,004.94		67,337.06	8.19
Dept 257 - ASSESSOR								
101-257-702.000	SALARIES & WAGES	60,734.00	60,734.00	6,946.50	6,946.50		53,787.50	11.44
101-257-705.000	EMPLOYER FICA CONTRIB	1,640.00	1,640.00	531.42	531.42		1,108.58	32.40
101-257-802.001	PROF SERVICES - ATTY	2,000.00	2,000.00	0.00	0.00		2,000.00	0.00
101-257-804.000	PROF SER SOFTWA	5,000.00	5,000.00	0.00	0.00		5,000.00	0.00
101-257-851.000	POSTAGE	3,000.00	3,000.00	0.00	0.00		3,000.00	0.00
101-257-955.000	MISCELLANEOUS	100.00	100.00	0.00	0.00		100.00	0.00
Total Dept 257 - ASSESSOR		72,474.00	72,474.00	7,477.92	7,477.92		64,996.08	10.32
Dept 262 - ELECTION								
101-262-702.000	SALARIES & WAGES	15,000.00	15,000.00	0.00	0.00		15,000.00	0.00
101-262-705.000	EMPLOYER FICA CONTRIB	1,200.00	1,200.00	0.00	0.00		1,200.00	0.00
101-262-752.000	SUPPLIES/EQUIPMENT	4,000.00	4,000.00	0.00	0.00		4,000.00	0.00
101-262-801.000	ELECT SERV VILLI	0.00	0.00	0.00	0.00		0.00	0.00

User: GLENN
 DB: PENTWATER TWP

GL NUMBER	DESCRIPTION	PERIOD ENDING 04/30/2026		YTD BALANCE 04/30/2026 NORM (ABNORM)	ACTIVITY FOR MONTH 04/30/26 INCR (DECR)	AVAILABLE BALANCE NORM (ABNORM)	% BDTG USED
		2026-27 ORIGINAL BUDGET	2026-27 AMENDED BUDGET				
Fund 101 - GENERAL FUND							
Expenditures							
101-262-802.000	ELECT OTHER CON	500.00	500.00	0.00	0.00	500.00	0.00
101-262-803.000	ELECTION SOURCE - CONTRACTUAL	4,000.00	4,000.00	0.00	0.00	4,000.00	0.00
101-262-815.000	EDUCATION/TRAINING	1,000.00	1,000.00	0.00	0.00	1,000.00	0.00
101-262-851.000	POSTAGE	2,000.00	2,000.00	0.00	0.00	2,000.00	0.00
101-262-860.000	TRAVEL EXPENSES	2,000.00	2,000.00	0.00	0.00	2,000.00	0.00
101-262-955.000	MISCELLANEOUS	1,500.00	1,500.00	0.00	0.00	1,500.00	0.00
101-262-970.003	CAP OUT OTHER	0.00	0.00	0.00	0.00	0.00	0.00
Total Dept 262 - ELECTION		31,200.00	31,200.00	0.00	0.00	31,200.00	0.00
Dept 265 - TOWNSHIP							
101-265-705.000	EMPLOYER FICA CONTRIB	501.00	501.00	68.37	68.37	432.63	13.65
101-265-706.000	CUSTODIAL WAGES	6,531.00	6,531.00	893.66	893.66	5,637.34	13.68
101-265-752.000	SUPPLIES/EQUIPMENT	8,000.00	8,000.00	170.50	170.50	7,829.50	2.13
101-265-802.000	PROF SERV SOFTWARE	6,000.00	6,000.00	2,989.61	2,989.61	3,010.39	49.83
101-265-804.000	PROF SERV-ATTOR	18,000.00	18,000.00	0.00	0.00	18,000.00	0.00
101-265-805.000	PROF SERV-AUDIT	7,000.00	7,000.00	0.00	0.00	7,000.00	0.00
101-265-806.000	OTHER SERVICES	0.00	0.00	0.00	0.00	0.00	0.00
101-265-806.001	PROF SERV IT	1,500.00	1,500.00	0.00	0.00	1,500.00	0.00
101-265-807.000	PROF SERV WEB	4,000.00	4,000.00	0.00	0.00	4,000.00	0.00
101-265-809.000	OTHER SERVICES	0.00	0.00	0.00	0.00	0.00	0.00
101-265-815.000	EDUCATION/TRAINING	800.00	800.00	0.00	0.00	800.00	0.00
101-265-820.000	PROF CONSULTANT	0.00	0.00	1,650.00	1,650.00	(1,650.00)	100.00
101-265-825.000	SUBSCRIPTIONS	400.00	400.00	0.00	0.00	400.00	0.00
101-265-828.000	BANK FEES	1,500.00	1,500.00	13.20	13.20	1,486.80	0.88
101-265-829.000	PERMITS	100.00	100.00	0.00	0.00	100.00	0.00
101-265-850.000	UTIL PH/INTERNE	4,200.00	4,200.00	308.84	308.84	3,891.16	7.35
101-265-851.000	POSTAGE	1,200.00	1,200.00	0.00	0.00	1,200.00	0.00
101-265-854.000	COPYING	1,800.00	1,800.00	0.00	0.00	1,800.00	0.00
101-265-855.000	OTHER SER/CHGS	2,200.00	2,200.00	183.86	183.86	2,016.14	8.36
101-265-860.000	TRAVEL EXPENSES	0.00	0.00	0.00	0.00	0.00	0.00
101-265-900.000	PRINT/PUBLISH	2,000.00	2,000.00	244.00	244.00	1,756.00	12.20
101-265-900.001	PRINT/PUB NOTIC	1,000.00	1,000.00	0.00	0.00	1,000.00	0.00
101-265-915.000	MEMBER/DUES	6,000.00	6,000.00	0.00	0.00	6,000.00	0.00
101-265-915.001	MEM/DUES MML	250.00	250.00	0.00	0.00	250.00	0.00
101-265-920.000	UTILITIES	8,000.00	8,000.00	264.64	264.64	7,735.36	3.31
101-265-931.000	REP/MAINT BUILDING	15,000.00	15,000.00	0.00	0.00	15,000.00	0.00
101-265-932.000	REP/MAIN MOW/SN	4,000.00	4,000.00	0.00	0.00	4,000.00	0.00
101-265-934.000	REP/MAIN CUSTOD	525.00	525.00	0.00	0.00	525.00	0.00
101-265-934.003	REP/MAIN MISC	700.00	700.00	0.00	0.00	700.00	0.00
101-265-935.000	INSURANCE/BONDS	6,000.00	6,000.00	0.00	0.00	6,000.00	0.00
101-265-937.000	WORK COMP	2,000.00	2,000.00	0.00	0.00	2,000.00	0.00
101-265-940.000	COPY MACH RENT	1,700.00	1,700.00	117.52	117.52	1,582.48	6.91
101-265-940.001	POST MACH RENT	3,000.00	3,000.00	0.00	0.00	3,000.00	0.00
101-265-955.000	MISCELLANEOUS	2,500.00	2,500.00	0.00	0.00	2,500.00	0.00
101-265-964.000	REFUNDS ASSESSOR CHANGES	400.00	400.00	175.80	175.80	224.20	43.95
101-265-970.000	CAP OUT-COMPUTE	0.00	0.00	0.00	0.00	0.00	0.00
101-265-970.002	CAP OUT-BLDG	0.00	0.00	0.00	0.00	0.00	0.00
101-265-991.100	DEBT SERVICE	0.00	0.00	0.00	0.00	0.00	0.00
101-265-995.000	TRANSFERS OUT	0.00	0.00	0.00	0.00	0.00	0.00
Total Dept 265 - TOWNSHIP		116,807.00	116,807.00	7,080.00	7,080.00	109,727.00	6.06

User: GLENN
 DB: PENTWATER TWP
 PERIOD ENDING 04/30/2026

GL NUMBER	DESCRIPTION	2026-27		YTD BALANCE		ACTIVITY FOR		AVAILABLE		% BGD
		ORIGINAL BUDGET	2026-27 AMENDED BUDGET	04/30/2026 NORM (ABNORM)	04/30/2026 NORM (ABNORM)	MONTH 04/30/26 INCR (DECR)	MONTH 04/30/26 INCR (DECR)	BALANCE NORM (ABNORM)	BALANCE NORM (ABNORM)	
Fund 101 - GENERAL FUND										
Expenditures										
101-445-875.000	AT LARGE DRAINAGE ASSESSMENT	20,000.00	20,000.00	0.00	0.00	0.00	0.00	20,000.00	20,000.00	0.00
Total Dept 445 - DRAIN		20,000.00	20,000.00	0.00	0.00	0.00	0.00	20,000.00	20,000.00	0.00
Dept 526 - TRANSFER STATION										
101-526-702.000	SALARIES & WAGES	17,975.00	17,975.00	2,154.06	2,154.06	2,154.06	2,154.06	15,820.94	15,820.94	11.98
101-526-705.000	EMPLOYER FICA CONTRIB	1,440.00	1,440.00	164.79	164.79	164.79	164.79	1,275.21	1,275.21	11.44
101-526-714.000	TSRC ASSISTANT	1,500.00	1,500.00	0.00	0.00	0.00	0.00	1,500.00	1,500.00	0.00
101-526-752.000	SUPPLIES/EQUIPMENT	500.00	500.00	185.00	185.00	185.00	185.00	315.00	315.00	37.00
101-526-815.000	TSRC EDUCATION/TRAINING	350.00	350.00	0.00	0.00	0.00	0.00	350.00	350.00	0.00
101-526-900.000	PRINT/PUBLISH	200.00	200.00	0.00	0.00	0.00	0.00	200.00	200.00	0.00
101-526-915.000	TSRC MEMBER/DUES	250.00	250.00	0.00	0.00	0.00	0.00	250.00	250.00	0.00
101-526-920.000	UTILITIES	750.00	750.00	0.00	0.00	0.00	0.00	750.00	750.00	0.00
101-526-934.000	REP/MAINT	5,000.00	5,000.00	0.00	0.00	0.00	0.00	5,000.00	5,000.00	0.00
101-526-935.000	INSURANCE/BONDS	2,600.00	2,600.00	0.00	0.00	0.00	0.00	2,600.00	2,600.00	0.00
101-526-940.000	RENTALS	25,000.00	25,000.00	0.00	0.00	0.00	0.00	23,271.50	23,271.50	6.91
101-526-940.001	EQUIP RENT/JOBS	1,300.00	1,300.00	115.00	115.00	115.00	115.00	1,185.00	1,185.00	8.85
101-526-956.000	MISCELLANEOUS	300.00	300.00	0.00	0.00	0.00	0.00	300.00	300.00	0.00
101-526-999.001	TSRC GRANT EXPENDITURES	0.00	0.00	0.00	0.00	0.00	0.00	0.00	0.00	0.00
Total Dept 526 - TRANSFER STATION		57,165.00	57,165.00	4,347.35	4,347.35	4,347.35	4,347.35	52,817.65	52,817.65	7.60
Dept 597 - DOC/RECREATION/PLIB										
101-597-802.000	CONT SER DOCK	800.00	800.00	0.00	0.00	0.00	0.00	800.00	800.00	0.00
101-597-804.000	CONT SERV REC	7,500.00	7,500.00	0.00	0.00	0.00	0.00	7,500.00	7,500.00	0.00
101-597-804.100	PARK PLACE	0.00	0.00	0.00	0.00	0.00	0.00	0.00	0.00	0.00
101-597-804.200	NORTHEND PARK	0.00	0.00	0.00	0.00	0.00	0.00	0.00	0.00	0.00
101-597-805.000	CONT SERV PLIB	6,350.00	6,350.00	0.00	0.00	0.00	0.00	6,350.00	6,350.00	0.00
101-597-808.000	BUOYS	1,000.00	1,000.00	0.00	0.00	0.00	0.00	1,000.00	1,000.00	0.00
101-597-934.000	REP/MAIN BOAT RAMP	15,000.00	15,000.00	0.00	0.00	0.00	0.00	15,000.00	15,000.00	0.00
101-597-955.000	MISCELLANEOUS	0.00	0.00	0.00	0.00	0.00	0.00	0.00	0.00	0.00
101-597-970.001	CAP OUTLAY - LB FISH DOCK	58,000.00	58,000.00	0.00	0.00	0.00	0.00	58,000.00	58,000.00	0.00
Total Dept 597 - DOC/RECREATION/PLIB		88,650.00	88,650.00	0.00	0.00	0.00	0.00	88,650.00	88,650.00	0.00
Dept 701 - PLANNING COMMISSION										
101-701-702.000	SALARIES/WAGES	5,000.00	5,000.00	645.50	645.50	645.50	645.50	4,354.50	4,354.50	12.91
101-701-705.000	EMPLOYER FICA CONTRIB	400.00	400.00	49.39	49.39	49.39	49.39	350.61	350.61	12.35
101-701-802.000	PROF SERV ATTORNEY	2,000.00	2,000.00	0.00	0.00	0.00	0.00	2,000.00	2,000.00	0.00
101-701-804.000	PROF SERV CONSULTANT	2,000.00	2,000.00	0.00	0.00	0.00	0.00	2,000.00	2,000.00	0.00
101-701-812.000	RECORDING SECRETARY	550.00	550.00	0.00	0.00	0.00	0.00	550.00	550.00	0.00
101-701-815.000	EDUCATION/TRAINING	200.00	200.00	0.00	0.00	0.00	0.00	200.00	200.00	0.00
101-701-851.000	POSTAGE	0.00	0.00	0.00	0.00	0.00	0.00	0.00	0.00	0.00
101-701-860.000	TRAVEL EXPENSES	50.00	50.00	0.00	0.00	0.00	0.00	50.00	50.00	0.00
101-701-900.000	NEWSPAPER PUBLICATIONS	500.00	500.00	0.00	0.00	0.00	0.00	500.00	500.00	0.00
101-701-955.000	MISCELLANEOUS	50.00	50.00	0.00	0.00	0.00	0.00	50.00	50.00	0.00
101-701-964.000	REFUNDS	440.00	440.00	0.00	0.00	0.00	0.00	440.00	440.00	0.00
Total Dept 701 - PLANNING COMMISSION		11,190.00	11,190.00	694.89	694.89	694.89	694.89	10,495.11	10,495.11	6.21
Dept 702 - ZONING ADMINISTRATION										
101-702-702.000	SALARIES & WAGES	38,539.00	38,539.00	4,408.01	4,408.01	4,408.01	4,408.01	34,130.99	34,130.99	11.44

User: GLENN
 DB: PENTWATER TWP
 PERIOD ENDING 04/30/2026

GL NUMBER	DESCRIPTION	2026-27		YTD BALANCE		ACTIVITY FOR		AVAILABLE		% BDT
		ORIGINAL BUDGET	AMENDED BUDGET	04/30/2026	04/30/2026	MONTH 04/30/26	INCR (DECR)	NORM (ABNRM)	BALANCE	
Fund 101 - GENERAL FUND										
Expenditures										
101-702-703.000	HEARING OFFICER WAGES	250.00	250.00	0.00	0.00	0.00	0.00	250.00	0.00	0.00
101-702-705.000	EMPLOYER FICA CONTRIBUTION	3,000.00	3,000.00	337.21	337.21	337.21	0.00	2,662.79	11.24	0.00
101-702-752.000	SUPPLIES/EQUIPMENT	50.00	50.00	0.00	0.00	0.00	0.00	50.00	0.00	0.00
101-702-802.000	PROF SERVICES	4,000.00	4,000.00	0.00	0.00	0.00	0.00	4,000.00	0.00	0.00
101-702-802.001	PROF SER ATTY	6,000.00	6,000.00	0.00	0.00	0.00	0.00	6,000.00	0.00	0.00
101-702-804.000	PROF SERV CONSU	1,500.00	1,500.00	0.00	0.00	0.00	0.00	1,500.00	0.00	0.00
101-702-815.000	EDUCATION/TRAINING	500.00	500.00	0.00	0.00	0.00	0.00	500.00	0.00	0.00
101-702-860.000	TRAVEL EXPENSES	600.00	600.00	0.00	0.00	0.00	0.00	600.00	0.00	0.00
101-702-900.000	PRINT/PUBLISH	1,000.00	1,000.00	0.00	0.00	0.00	0.00	1,000.00	0.00	0.00
101-702-955.000	MISCELLANEOUS	50.00	50.00	0.00	0.00	0.00	0.00	50.00	0.00	0.00
101-702-964.000	REFUNDS	440.00	440.00	0.00	0.00	0.00	0.00	440.00	0.00	0.00
Total Dept 702 - ZONING ADMINISTRATION		55,929.00	55,929.00	4,745.22	4,745.22	4,745.22	0.00	51,183.78	8.48	0.00
Dept 703 - ZONING BOARD OF APPEALS										
SALARIES & WAGES										
101-703-702.000	EMPLOYER FICA CONTRIB	1,500.00	1,500.00	0.00	0.00	0.00	0.00	1,500.00	0.00	0.00
101-703-705.000	PROF SERV ATTY	1,000.00	1,000.00	0.00	0.00	0.00	0.00	1,000.00	0.00	0.00
101-703-812.000	REC SECRETARY	225.00	225.00	0.00	0.00	0.00	0.00	225.00	0.00	0.00
101-703-815.000	EDUCATION/TRAINING	300.00	300.00	0.00	0.00	0.00	0.00	300.00	0.00	0.00
101-703-860.000	TRAVEL EXPENSES	50.00	50.00	0.00	0.00	0.00	0.00	50.00	0.00	0.00
101-703-900.000	PRINT/PUBLISH	900.00	900.00	0.00	0.00	0.00	0.00	900.00	0.00	0.00
101-703-955.000	MISCELLANEOUS	100.00	100.00	0.00	0.00	0.00	0.00	100.00	0.00	0.00
101-703-964.000	REFUNDS	440.00	440.00	0.00	0.00	0.00	0.00	440.00	0.00	0.00
Total Dept 703 - ZONING BOARD OF APPEALS		4,740.00	4,740.00	0.00	0.00	0.00	0.00	4,740.00	0.00	0.00
TOTAL EXPENDITURES		668,787.00	668,787.00	44,988.37	44,988.37	44,988.37	0.00	623,798.63	6.73	0.00
Fund 101 - GENERAL FUND:										
TOTAL REVENUES		668,787.00	668,787.00	169,364.57	169,364.57	169,364.57	0.00	499,422.43	25.32	0.00
TOTAL EXPENDITURES		668,787.00	668,787.00	44,988.37	44,988.37	44,988.37	0.00	623,798.63	6.73	0.00
NET OF REVENUES & EXPENDITURES		0.00	0.00	124,376.20	124,376.20	124,376.20	0.00	(124,376.20)	100.00	0.00

User: GLENN
 DB: PENTWATER TWP
 PERIOD ENDING 04/30/2026

GL NUMBER	DESCRIPTION	2026-27		YTD BALANCE		ACTIVITY FOR		AVAILABLE		% BGD
		ORIGINAL BUDGET	AMENDED BUDGET	04/30/2026	NORM (ABNORM)	MONTH 04/30/26	INCR (DECR)	NORM (ABNORM)	BALANCE	
Fund 204 - ROAD FUND										
Revenues										
204-000-400.000	FROM PREV YEAR END	986.00	986.00	0.00		0.00		986.00		0.00
204-000-402.000	CURRENT REAL PR	142,500.00	142,500.00	55,692.45		55,692.45		86,807.55		39.08
204-000-411.000	DEL REAL P TAX	7,500.00	7,500.00	0.00		0.00		7,500.00		0.00
204-000-664.000	INTEREST INCOME	2,500.00	2,500.00	0.00		0.00		2,500.00		0.00
204-000-679.000	REIMBURSEMENT REVENUE APACHE HILLS	0.00	0.00	0.00		0.00		0.00		0.00
204-000-699.000	TRANSFER IN	0.00	0.00	0.00		0.00		0.00		0.00
Total Dept 000		153,486.00	153,486.00	55,692.45		55,692.45		97,793.55		36.29
TOTAL REVENUES										
153,486.00		153,486.00	153,486.00	55,692.45		55,692.45		97,793.55		36.29
Expenditures										
Dept 000										
204-000-702.000	SALARIES & WAGES	1,798.00	1,798.00	0.00		0.00		1,798.00		0.00
204-000-705.000	EMPLOYER FICA CONTRIB	138.00	138.00	0.00		0.00		138.00		0.00
204-000-805.000	PROF SERV-AUDIT	1,000.00	1,000.00	0.00		0.00		1,000.00		0.00
204-000-855.000	OTHER SER/CHGS	1,550.00	1,550.00	479.00		479.00		1,071.00		30.90
204-000-930.000	REP/MAIN BRINE	13,000.00	13,000.00	0.00		0.00		13,000.00		0.00
204-000-934.002	REP/MAIN INTERI	136,000.00	136,000.00	0.00		0.00		136,000.00		0.00
204-000-934.004	REP/MAIN APACHE HILLS	0.00	0.00	0.00		0.00		0.00		0.00
204-000-964.000	REFUNDS DUE TO ASSESSOR CHANGES	0.00	0.00	34.25		34.25		(34.25)		100.00
Total Dept 000		153,486.00	153,486.00	513.25		513.25		152,972.75		0.33
TOTAL EXPENDITURES										
153,486.00		153,486.00	153,486.00	513.25		513.25		152,972.75		0.33
Fund 204 - ROAD FUND:										
TOTAL REVENUES										
153,486.00		153,486.00	153,486.00	55,692.45		55,692.45		97,793.55		36.29
TOTAL EXPENDITURES										
153,486.00		153,486.00	153,486.00	513.25		513.25		152,972.75		0.33
NET OF REVENUES & EXPENDITURES										
0.00		0.00	0.00	55,179.20		55,179.20		(55,179.20)		100.00

User: GLENN
 DB: PENTWATER TWP
 PERIOD ENDING 04/30/2026

GL NUMBER	DESCRIPTION	2026-27		YTD BALANCE		ACTIVITY FOR		AVAILABLE	
		ORIGINAL BUDGET	AMENDED BUDGET	04/30/2026	NORM (ABNORM)	MONTH 04/30/26	INCR (DECR)	BALANCE	% BDTG
Fund 206 - FIRE FUND									
Expenditures									
206-336-968.001	LOSS ON DISPOSAL CAPITAL ASSET	0.00	0.00	0.00	0.00	0.00	0.00	0.00	0.00
206-336-970.000	CAPITAL OUTLAY	46,391.00	46,391.00	0.00	0.00	0.00	0.00	46,391.00	0.00
206-336-977.000	FUTURE EQP/IMP	22,222.00	22,222.00	0.00	0.00	0.00	0.00	22,222.00	0.00
206-336-991.000	DEBT SERVICE	0.00	0.00	0.00	0.00	0.00	0.00	0.00	0.00
206-336-991.100	DEBT SERVICE - PRINCIPAL	119,334.00	119,334.00	119,333.35	119,333.35	119,333.35	119,333.35	0.65	100.00
206-336-991.200	DEBT SERVICE - INTEREST	570.00	570.00	569.98	569.98	569.98	569.98	0.02	100.00
Total Dept 336 - FIRE		489,650.00	489,650.00	187,838.13	187,838.13	187,838.13	187,838.13	301,811.87	38.36
TOTAL EXPENDITURES		489,650.00	489,650.00	187,838.13	187,838.13	187,838.13	187,838.13	301,811.87	38.36
Fund 206 - FIRE FUND:									
TOTAL REVENUES		489,650.00	489,650.00	165,850.74	165,850.74	165,850.74	165,850.74	323,799.26	33.87
TOTAL EXPENDITURES		489,650.00	489,650.00	187,838.13	187,838.13	187,838.13	187,838.13	301,811.87	38.36
NET OF REVENUES & EXPENDITURES		0.00	0.00	(21,987.39)	(21,987.39)	(21,987.39)	(21,987.39)	21,987.39	100.00

PERIOD ENDING 04/30/2026

GL NUMBER	DESCRIPTION	2026-27		YTD BALANCE		ACTIVITY FOR		AVAILABLE	
		ORIGINAL BUDGET	2026-27 AMENDED BUDGET	04/30/2026 NORM (ABNORM)	04/30/2026 NORM (ABNORM)	MONTH 04/30/26 INCR (DECR)	BALANCE	NORM (ABNORM)	% BGD USED
Fund 209 - CEMETERY FUND									
Revenues									
Dept 000									
209-000-401.000	PAR PREV YE BAL	0.00	0.00	0.00	0.00	0.00	0.00	0.00	0.00
209-000-402.000	CURR PROP TAX	95,000.00	95,000.00	37,374.96	37,374.96	37,374.96	57,625.04	39.34	39.34
209-000-411.000	DEL REAL PP TAX	5,000.00	5,000.00	0.00	0.00	0.00	5,000.00	0.00	0.00
209-000-626.000	INTERMENT FEES	3,500.00	3,500.00	0.00	0.00	0.00	3,500.00	0.00	0.00
209-000-644.000	CEMETERY FOUNDATION	3,000.00	3,000.00	0.00	0.00	0.00	3,000.00	0.00	0.00
209-000-645.000	LOT SALES	6,000.00	6,000.00	200.00	200.00	200.00	5,800.00	3.33	3.33
209-000-646.000	COLUM SALES	2,000.00	2,000.00	1,600.00	1,600.00	1,600.00	400.00	80.00	80.00
209-000-647.000	SCAT GAR BRICK	100.00	100.00	0.00	0.00	0.00	100.00	0.00	0.00
209-000-664.000	INTEREST INCOME	12,000.00	12,000.00	0.00	0.00	0.00	12,000.00	0.00	0.00
209-000-671.000	OTHER INCOME	1,500.00	1,500.00	0.00	0.00	0.00	1,500.00	0.00	0.00
209-000-699.000	TRANSFER IN	0.00	0.00	0.00	0.00	0.00	0.00	0.00	0.00
Total Dept 000		128,100.00	128,100.00	39,174.96	39,174.96	39,174.96	88,925.04	30.58	30.58
TOTAL REVENUES		128,100.00	128,100.00	39,174.96	39,174.96	39,174.96	88,925.04	30.58	30.58

Expenditures

Dept 567 - CEMETERY									
209-567-702.000	SALARIES & WAGES	27,873.00	27,873.00	3,187.64	3,187.64	3,187.64	24,685.36	11.44	11.44
209-567-703.000	PAYROLL EXPENSE	0.00	0.00	0.00	0.00	0.00	0.00	0.00	0.00
209-567-704.001	CEMETERY ASSISTANT	3,333.00	3,333.00	265.14	265.14	265.14	3,067.86	7.95	7.95
209-567-705.000	EMPLOYER FICA CONTRIB	2,500.00	2,500.00	264.14	264.14	264.14	2,235.86	10.57	10.57
209-567-752.000	SUPPLIES/EQUIPMENT	5,300.00	5,300.00	1,381.83	1,381.83	1,381.83	3,918.17	26.07	26.07
209-567-801.000	PROF SERV-ATTOR	1,700.00	1,700.00	0.00	0.00	0.00	1,700.00	0.00	0.00
209-567-802.000	PRO SERV SOFTWA	3,000.00	3,000.00	404.00	404.00	404.00	2,596.00	13.47	13.47
209-567-804.000	PROF SERV MAP	300.00	300.00	0.00	0.00	0.00	300.00	0.00	0.00
209-567-805.000	PRO SERV AUDIT	900.00	900.00	0.00	0.00	0.00	900.00	0.00	0.00
209-567-806.000	COLUM PLAQUES	4,000.00	4,000.00	154.20	154.20	154.20	3,845.80	3.86	3.86
209-567-807.000	BRICK ENGRAVING	300.00	300.00	0.00	0.00	0.00	300.00	0.00	0.00
209-567-810.000	FOUNDATION EXP	1,000.00	1,000.00	0.00	0.00	0.00	1,000.00	0.00	0.00
209-567-815.000	EDUCATION/TRAINING	0.00	0.00	0.00	0.00	0.00	0.00	0.00	0.00
209-567-851.000	POSTAGE	100.00	100.00	0.00	0.00	0.00	100.00	0.00	0.00
209-567-855.000	OTHER SER/CHGS	50.00	50.00	0.00	0.00	0.00	50.00	0.00	0.00
209-567-900.000	PRINT/PUBLISH	350.00	350.00	0.00	0.00	0.00	350.00	0.00	0.00
209-567-920.000	UTILITIES	3,000.00	3,000.00	104.08	104.08	104.08	2,895.92	3.47	3.47
209-567-928.000	REFUNDS	500.00	500.00	112.00	112.00	112.00	388.00	22.40	22.40
209-567-930.000	REP/MAINT BLDGS	500.00	500.00	0.00	0.00	0.00	500.00	0.00	0.00
209-567-930.001	REP/MAINT GROUN	14,000.00	14,000.00	3,795.00	3,795.00	3,795.00	10,205.00	27.11	27.11
209-567-931.000	REP/MAINT EQUIP	2,000.00	2,000.00	0.00	0.00	0.00	2,000.00	0.00	0.00
209-567-931.001	REP/MAINT IRRIG	14,000.00	14,000.00	0.00	0.00	0.00	14,000.00	0.00	0.00
209-567-935.000	INSURANCE	3,500.00	3,500.00	0.00	0.00	0.00	3,500.00	0.00	0.00
209-567-955.000	MISCELLANEOUS	1,300.00	1,300.00	0.00	0.00	0.00	1,300.00	0.00	0.00
209-567-970.000	CAPITAL OUTLAY	38,594.00	38,594.00	10,192.69	10,192.69	10,192.69	28,401.31	26.41	26.41
Total Dept 567 - CEMETERY		128,100.00	128,100.00	19,860.72	19,860.72	19,860.72	108,239.28	15.50	15.50
TOTAL EXPENDITURES		128,100.00	128,100.00	19,860.72	19,860.72	19,860.72	108,239.28	15.50	15.50

Fund 209 - CEMETERY FUND:

TOTAL REVENUES		128,100.00	128,100.00	39,174.96	39,174.96	39,174.96	88,925.04	30.58	30.58
----------------	--	------------	------------	-----------	-----------	-----------	-----------	-------	-------

PERIOD ENDING 04/30/2026

GL NUMBER	DESCRIPTION	2026-27 ORIGINAL BUDGET	2026-27 AMENDED BUDGET	YTD BALANCE 04/30/2026 NORM (ABNORM)	ACTIVITY FOR MONTH 04/30/26 INCR (DECR)	AVAILABLE BALANCE NORM (ABNORM)	% BDGT USED
Fund 209 - CEMETERY FUND		128,100.00	128,100.00	19,860.72	19,860.72	108,239.28	15.50
TOTAL EXPENDITURES		0.00	0.00	19,314.24	19,314.24	(19,314.24)	100.00
NET OF REVENUES & EXPENDITURES							

User: GLENN
 DB: PENTWATER TWP

PERIOD ENDING 04/30/2026

GL NUMBER	DESCRIPTION	2026-27		YTD BALANCE 04/30/2026 NORM (ABNORM)	ACTIVITY FOR MONTH 04/30/26 INCR (DECR)	AVAILABLE BALANCE NORM (ABNORM)	% BDCG USED
		ORIGINAL BUDGET	AMENDED BUDGET				
Fund 592 - SEWER FUND							
Expenditures							
592-539-970.006	CAPITAL OUTLAY - SEWER	2,000.00	2,000.00	0.00	0.00	2,000.00	0.00
592-539-991.100	DEBT SERVICE - PRINCIPAL	0.00	0.00	0.00	0.00	0.00	0.00
592-539-991.200	DEBT SERVICE - INTEREST	2,750.00	2,750.00	0.00	0.00	2,750.00	0.00
Total Dept 539 - SHARED N&S SEWER ADMINISTRATION		19,100.00	19,100.00	876.74	876.74	18,223.26	4.59
Dept 540 - TWP NORTH SEWER EXPENDITURES							
592-540-752.000	SUPPLIES/EQUIPMENT	500.00	500.00	0.00	0.00	500.00	0.00
592-540-800.000	PROF/CONTRACT SERVICES	30,000.00	30,000.00	1,273.25	1,273.25	28,726.75	4.24
592-540-920.000	UTILITIES	2,000.00	2,000.00	142.98	142.98	1,857.02	7.15
592-540-920.001	VILLAGE UTILITIES	40,000.00	40,000.00	11,523.00	11,523.00	28,477.00	28.81
592-540-931.000	REP/MAINT	1,500.00	1,500.00	0.00	0.00	1,500.00	0.00
592-540-942.000	EQUIPMENT RENTAL	500.00	500.00	0.00	0.00	500.00	0.00
592-540-970.006	CAPITAL OUTLAY - SEWER	6,000.00	6,000.00	0.00	0.00	6,000.00	0.00
592-540-991.100	DEBT SERVICE - PRINCIPAL	0.00	0.00	0.00	0.00	0.00	0.00
592-540-991.200	DEBT SERVICE - INTEREST	0.00	0.00	0.00	0.00	0.00	0.00
Total Dept 540 - TWP NORTH SEWER EXPENDITURES		80,500.00	80,500.00	12,939.23	12,939.23	67,560.77	16.07
Dept 541 - TWP SOUTH SEWER EXPENDITURES							
592-541-752.000	SUPPLIES/EQUIPMENT	500.00	500.00	0.00	0.00	500.00	0.00
592-541-800.000	PROF/CONTRACT SERVICES	15,000.00	15,000.00	1,343.35	1,343.35	13,656.65	8.96
592-541-829.000	STATE PERMITS	2,000.00	2,000.00	0.00	0.00	2,000.00	0.00
592-541-920.000	UTILITIES	5,000.00	5,000.00	443.89	443.89	4,556.11	8.88
592-541-931.000	REP/MAINT	10,000.00	10,000.00	0.00	0.00	10,000.00	0.00
592-541-942.000	EQUIPMENT RENTAL	500.00	500.00	0.00	0.00	500.00	0.00
592-541-970.006	CAPITAL OUTLAY - SEWER	6,000.00	6,000.00	0.00	0.00	6,000.00	0.00
592-541-991.100	DEBT SERVICE - PRINCIPAL	0.00	0.00	0.00	0.00	0.00	0.00
592-541-991.200	DEBT SERVICE - INTEREST	0.00	0.00	0.00	0.00	0.00	0.00
Total Dept 541 - TWP SOUTH SEWER EXPENDITURES		39,000.00	39,000.00	1,787.24	1,787.24	37,212.76	4.58
TOTAL EXPENDITURES		167,950.00	167,950.00	17,882.66	17,882.66	150,067.34	10.65
Fund 592 - SEWER FUND:							
TOTAL REVENUES		185,900.00	185,900.00	40,553.00	40,553.00	145,347.00	21.81
TOTAL EXPENDITURES		167,950.00	167,950.00	17,882.66	17,882.66	150,067.34	10.65
NET OF REVENUES & EXPENDITURES		17,950.00	17,950.00	22,670.34	22,670.34	(4,720.34)	126.30
TOTAL REVENUES - ALL FUNDS							
TOTAL EXPENDITURES - ALL FUNDS		1,625,923.00	1,625,923.00	470,635.72	470,635.72	1,155,287.28	28.95
NET OF REVENUES & EXPENDITURES		1,607,973.00	1,607,973.00	271,083.13	271,083.13	1,336,889.87	16.86
NET OF REVENUES & EXPENDITURES		17,950.00	17,950.00	199,552.59	199,552.59	(181,602.59)	1,111.71

User: GLENN POST DATES 04/01/2026 - 04/30/2026
 DB: PENTWATER TWP BOTH JOURNALIZED AND UNJOURNALIZED OPEN AND PAID

BANK CODE: GFPO

Inv Ref#	Vendor	Inv Date	Due Date	Inv Amt	Amt Due	Status	Jrnalized
4356	SHOTWELL SOLUTIONS LLC	04/01/2026	04/01/2026	708.42	0.00	Paid	Y
4358	ANAVON TECHNOLOGY GROUP	04/01/2026	04/02/2026	128.84	0.00	Paid	Y
4363	AMERICAN CLASSIC DUMPSTER SERVICE	04/02/2026	04/02/2026	345.00	0.00	Paid	Y
4365	CHARTER COMMUNICATIONS	04/01/2026	04/07/2026	180.00	0.00	Paid	Y
4366	CONSUMERS ENERGY	04/01/2026	04/07/2026	25.08	0.00	Paid	Y
4367	CONSUMERS ENERGY	04/01/2026	04/07/2026	99.31	0.00	Paid	Y
4368	PLANTE MORAN, PLLC	03/27/2026	04/07/2026	2,327.50	0.00	Paid	Y
4369	OCEANA COUNTY TREASURER	04/06/2026	04/09/2026	172.10	0.00	Paid	Y
4370	CINTAS	04/09/2026	04/09/2026	91.93	0.00	Paid	Y
4371	HOLLAND SUPPLY	04/07/2026	04/09/2026	459.72	0.00	Paid	Y
4372	KLOTZ AUTO PARTS	04/06/2026	04/09/2026	39.83	0.00	Paid	Y
4373	PENTWATER CONVENIENCE CENTER	04/06/2026	04/09/2026	65.20	0.00	Paid	Y
4375	CONSUMERS ENERGY	04/07/2026	04/10/2026	13.76	0.00	Paid	Y
4376	CONSUMERS ENERGY	04/06/2026	04/10/2026	23.11	0.00	Paid	Y
4377	THOMAS ROOSE	04/15/2026	04/15/2026	5,000.00	0.00	Paid	Y
4378	LYNN ROOSE	04/15/2026	04/15/2026	5,000.00	0.00	Paid	Y
4379*	CONSUMERS CREDIT UNION	04/02/2026	04/16/2026	603.06	0.00	Paid	Y
4380	AMERICAN CLASSIC DUMPSTER SERVICE	04/08/2026	04/16/2026	550.00	0.00	Paid	Y
4381	BS&A SOFTWARE	04/16/2026	04/16/2026	3,279.00	0.00	Paid	Y
4382	DTE ENERGY	04/07/2026	04/16/2026	140.25	0.00	Paid	Y
4383	DTE ENERGY	04/07/2026	04/16/2026	63.08	0.00	Paid	Y
4384	SEYMOUR' SALES & SERVICE	04/01/2026	04/16/2026	63.88	0.00	Paid	Y
4385	US POSTAL SERVICE	04/08/2026	04/16/2026	78.00	0.00	Paid	Y
4387	F&V OPERATIONS	04/17/2026	04/22/2026	547.45	0.00	Paid	Y
4388	F&V OPERATIONS	04/17/2026	04/22/2026	198.00	0.00	Paid	Y
4389	F&V OPERATIONS	04/17/2026	04/22/2026	1,273.25	0.00	Paid	Y
4390	F&V OPERATIONS	04/17/2026	04/22/2026	1,343.35	0.00	Paid	Y
4391	GLENN C BEAVIS	04/20/2026	04/22/2026	192.69	0.00	Paid	Y
4392	GREAT LAKES ENERGY	04/15/2026	04/22/2026	380.81	0.00	Paid	Y
4393	HOLLAND SUPPLY	04/16/2026	04/22/2026	445.39	0.00	Paid	Y
4394	JONS TO GO	04/21/2026	04/22/2026	115.00	0.00	Paid	Y
4395	PENTWATER CONVENIENCE CENTER	03/20/2026	04/22/2026	185.00	0.00	Paid	Y
4396	PENTWATER CONVENIENCE CENTER	10/13/2025	04/22/2026	134.75	0.00	Paid	Y
4398	CINTAS	04/23/2026	04/23/2026	91.93	0.00	Paid	Y
4399	AMERICAN CLASSIC DUMPSTER SERVICE	04/24/2026	04/30/2026	833.50	0.00	Paid	Y
4400	COLDSPRING	04/29/2026	04/30/2026	154.20	0.00	Paid	Y
4401	CONSUMERS ENERGY	04/24/2026	04/30/2026	29.50	0.00	Paid	Y
4402	CONSUMERS ENERGY	04/24/2026	04/30/2026	37.71	0.00	Paid	Y
4403	CONSUMERS ENERGY	04/23/2026	04/30/2026	66.39	0.00	Paid	Y
4404	CONSUMERS ENERGY	04/23/2026	04/30/2026	76.59	0.00	Paid	Y
4405	DISABILITY NETWORK OF WEST MICHIG	04/23/2026	04/30/2026	1,650.00	0.00	Paid	Y
4406	ECHO PUBLISHING INC	04/29/2026	04/30/2026	1,442.00	0.00	Paid	Y
4407	INTEGRITY BUSINESS SOLUTIONS	04/27/2026	04/30/2026	80.03	0.00	Paid	Y
4408	INTEGRITY BUSINESS SOLUTIONS	04/29/2026	04/30/2026	20.28	0.00	Paid	Y
4409	LARSON AND SON	04/22/2026	04/30/2026	96.95	0.00	Paid	Y
4410	OCEANA COUNTY TREASURER	04/21/2026	04/30/2026	60.94	0.00	Paid	Y
4411	PLANTE MORAN, PLLC	04/16/2026	04/30/2026	855.00	0.00	Paid	Y

new
DEM
TRUCK

INVOICE REGISTER REPORT FOR PENTWATER TOWNSHIP
 POST DATES 04/01/2026 - 04/30/2026
 BOTH JOURNALIZED AND UNJOURNALIZED OPEN AND PAID
 BANK CODE: GPPOL

User: GLENN
 DB: PENTWATER TWP

Inv Ref#	Vendor	Inv Date	Due Date	Inv Amt	Amt Due	Status	Jrnalized
4412	RICOH USA, INC - 1	04/17/2026	04/30/2026	117.52	0.00	Paid	Y
4413	POSTMA MONUMENT INC.	04/30/2026	04/30/2026	112.00	0.00	Paid	Y
4414	RYANS LAWN CARE	04/28/2026	04/30/2026	3,795.00	0.00	Paid	Y
4415	VILLAGE OF PENTWATER - UTILITIES	04/23/2026	04/30/2026	11,523.00	0.00	Paid	Y
# of Invoices:	51 # Due:	0	Totals:	45,315.30	0.00		
# of Credit Memos:	0 # Due:	0	Totals:	0.00	0.00		
Net of Invoices and Credit Memos:				45,315.30	0.00		
* 1 Net Invoices have Credits Totalling:				(47.98)			
--- TOTALS BY FUND ---							
101 - GENERAL FUND				11,629.34	0.00		
204 - ROAD FUND				513.25	0.00		
209 - CEMETERY FUND				16,166.79	0.00		
592 - SEWER FUND				17,005.92	0.00		
--- TOTALS BY DEPT/ACTIVITY ---							
000 -				513.25	0.00		
253 - TREASURER				1,155.37	0.00		
265 - TOWNSHIP				8,445.47	0.00		
336 - FIRE				22.99	0.00		
526 - TRANSFER STATION				2,028.50	0.00		
538 - SHARED N&S SEWER EXPENDITUR				2,279.45	0.00		
540 - TWP NORTH SEWER EXPENDITURE				12,939.23	0.00		
541 - TWP SOUTH SEWER EXPENDITURE				1,787.24	0.00		
567 - CEMETERY				16,143.80	0.00		

INVOICE REGISTER REPORT FOR PENTWATER TOWNSHIP

User: GLENN
 DB: PENTWATER TWP
 POST DATES 04/01/2026 - 04/30/2026

BOTH JOURNALIZED AND UNJOURNALIZED OPEN AND PAID

BANK CODE: FDCHK

Inv Ref#	Vendor	Inv Date	Due Date	Inv Amt	Amt Due	Status	Jrnalized
4359	AMERICAN CLASSIC DUMPSTER SERVICE	04/02/2026	04/02/2026	100.00	0.00	Paid	Y
4374	OCEANA COUNTY TREASURER	04/06/2026	04/09/2026	102.01	0.00	Paid	Y
4386	BS&A SOFTWARE	04/16/2026	04/16/2026	987.00	0.00	Paid	Y
4397	WESTSHORE BANK	04/16/2026	04/22/2026	119,903.33	0.00	Paid	Y
4416	ADVANTAGE FLEET	03/26/2026	04/30/2026	1,367.30	0.00	Paid	Y
4417	BHS	04/01/2026	04/30/2026	28,206.00	0.00	Paid	Y
4418	CHARTER COMMUNICATIONS	04/01/2026	04/30/2026	313.08	0.00	Paid	Y
# of Invoices:		7	# Due:	0			
# of Credit Memos:		0	# Due:	0			
Totals:				150,978.72	0.00		
Totals:				0.00	0.00		
Net of Invoices and Credit Memos:				150,978.72	0.00		

--- TOTALS BY FUND ---
 206 - FIRE FUND 0.00

--- TOTALS BY DEPT/ACTIVITY ---
 336 - FIRE 0.00

Check Register Report For Pentwater Township
For Check Dates 04/01/2026 to 04/30/2026

Check Date	Bank	Check Number	Check Name	Check Gross	Physical Check Amount	Direct Deposit Status
04/16/2026	GFPOL	DD498	FLOOD, JOSEPH M	300.52	0.00	264.76 Open
04/16/2026	GFPOL	DD499	FLYNN, MICHAEL W	149.31	0.00	121.53 Open
04/16/2026	GFPOL	DD500	HOLUB, DEAN J	149.31	0.00	131.54 Open
04/16/2026	GFPOL	DD501	MILLER, ROBERT A	689.88	0.00	615.02 Open
04/16/2026	GFPOL	DD502	MURPHY, MAUREEN H	1,523.15	0.00	1,320.98 Open
04/16/2026	GFPOL	DD503	MURPHY, MAUREEN H	307.58	0.00	270.98 Open
04/16/2026	GFPOL	EFT325	POOLED FEDERAL TAXES	3,024.22	3,024.22	0.00 Open
04/02/2026	GFPOL	DD476	BAILEY, CHRISTOPHER R.	744.23	0.00	662.45 Open
04/02/2026	GFPOL	DD477	BEAVIS, GLENN C	1,335.65	0.00	886.49 Open
04/02/2026	GFPOL	DD478	CAVAZOS, LYNNETTE M	1,483.08	0.00	1,172.78 Open
04/02/2026	GFPOL	DD479	DOUGLAS, HEATHER A	1,483.08	0.00	1,289.69 Open
04/02/2026	GFPOL	DD480	DOUGLAS, HEATHER A	166.39	0.00	153.67 Open
04/02/2026	GFPOL	DD481	EATON, BARBARA C	2,274.50	0.00	1,520.29 Open
04/02/2026	GFPOL	DD482	EDWARDS, KEITH J	1,616.35	0.00	1,388.96 Open
04/02/2026	GFPOL	DD483	EDWARDS, KEITH J	173.04	0.00	159.80 Open
04/02/2026	GFPOL	DD484	FLOOD, DEBRA A	281.19	0.00	243.19 Open
04/02/2026	GFPOL	DD485	FLOOD, JOSEPH M	292.62	0.00	257.79 Open
04/02/2026	GFPOL	DD486	MILLER, ROBERT A	774.30	0.00	680.93 Open
04/02/2026	GFPOL	DD487	MURPHY, MAUREEN H	1,483.08	0.00	1,289.70 Open
04/02/2026	GFPOL	DD488	MURPHY, MAUREEN H	299.49	0.00	263.85 Open
04/02/2026	GFPOL	EFT323	POOLED FEDERAL TAXES	2,975.55	2,975.55	0.00 Open

Totals: 47,313.33 9,101.34 30,751.07

Total Physical Checks: 051

Total Check Stubs: 51

Check Register Report For Pentwater Township
For Check Dates 04/01/2026 to 04/30/2026

Check Date	Bank	Check Number	Check Number Name	Check Gross	Physical Check Amount	Direct Deposit Status
04/02/2026	FDCHK	DD457	BAREFOOT, MICHAEL S	3,770.00	0.00	3,296.36 Open
04/02/2026	FDCHK	DD458	BOYKO, AARON N.	1,380.00	0.00	1,249.43 Open
04/02/2026	FDCHK	DD459	DILLINGHAM, KYLE W	2,240.00	0.00	2,043.64 Open
04/02/2026	FDCHK	DD460	ESQUIVEL, OSCAR A	2,000.00	0.00	1,737.00 Open
04/02/2026	FDCHK	DD461	HARTRUM, LAUDE E	150.00	0.00	107.14 Open
04/02/2026	FDCHK	DD462	HAYNOR, MARK R.	1,830.00	0.00	1,612.22 Open
04/02/2026	FDCHK	DD463	HUGHART, JONATHAN D.	6,630.00	0.00	5,816.02 Open
04/02/2026	FDCHK	DD464	KOKX, ADAM J	3,600.00	0.00	3,299.60 Open
04/02/2026	FDCHK	DD465	KOKX, KATIE MAY	2,880.00	0.00	2,512.28 Open
04/02/2026	FDCHK	DD466	MALBURG, JOSEPH R.	1,620.00	0.00	1,471.07 Open
04/02/2026	FDCHK	DD467	MALONEY, TROY	510.00	0.00	424.30 Open
04/02/2026	FDCHK	DD468	MITCHELL, DARWIN D	810.00	0.00	688.60 Open
04/02/2026	FDCHK	DD469	RESKE, CHRISTOPHER A	60.00	0.00	27.86 Open
04/02/2026	FDCHK	DD470	SMITH, KAREN R	160.00	0.00	147.76 Open
04/02/2026	FDCHK	DD471	THOCHER, ZACHARY J	1,140.00	0.00	979.34 Open
04/02/2026	FDCHK	DD472	THOMPSON, DALE W	2,070.00	0.00	1,798.66 Open
04/02/2026	FDCHK	DD473	VAN DUINEN, ANNA R	150.00	0.00	107.14 Open
04/02/2026	FDCHK	DD474	VANDUINEN, BRADLEY J	1,950.00	0.00	1,692.94 Open
04/02/2026	FDCHK	DD475	WOOD, ETHAN T	1,290.00	0.00	1,111.48 Open
04/02/2026	FDCHK	EFT322	EFTPS FIRE	5,238.82	5,238.82	0.00 Open
04/02/2026	FDCHK	EFT324	PENTWATER FIRE DEPT. ASSOCIATION	425.00	425.00	0.00 Open

Totals: Number of Checks: 021 39,903.82 5,663.82 30,122.84

Total Physical Checks:
Total Check Stubs:

*BI-ANNUAL
FD PAYROLL*



PENTWATER FIRE DEPARTMENT

486 E Park St • PO Box 1117
Pentwater, MI 49449

Phone 231.869.5987 • Fax 231.869.8511
www.pentwaterfiredepartment.com

Monthly Meeting Agenda

Meeting Date: No April Business Meeting
Meeting Location: Pentwater Fire Department
Call to Order

- I. No April Business Meeting, Next Meeting May 6, 2026
- II. Reports of Officers
 - a. Treasurer Brad Van Duinen
 - i. Ending Payroll - \$44,960
 1. \$34,240 payroll through 3/24/2026
 2. \$10,720 payroll for balance of March 2026
 - ii. Checking - \$250,040.93
 - iii. CLASS - \$257,272.01
 - iv. EDGE - \$0.00
 - v. Total Funds - \$507,312.94
 - vi. Funds Net Payroll - \$462,352.94
- III. Discussion on Last Months' Calls-
 - a. 16 medical, 8 fire and 1 UAV call for service in March



PENTWATER FIRE DEPARTMENT

486 E Park St • PO Box 1117
Pentwater, MI 49449

Phone 231.869.5987 • Fax 231.869.8511
www.pentwaterfiredepartment.com

Officers Meeting Agenda

Meeting Date: No April Business Meeting
Meeting Location: Pentwater Fire Department
Call to Order

Please note- the agenda for the Officer Meeting is the same as the regular monthly meeting and items are often discussed at both meetings.

- I. No April Business Meeting, Next Meeting May 6, 2026
- II. Reports of Officers
 - a. Treasurer Brad Van Duinen
 - i. Ending Payroll - \$44,960
 1. \$34,240 payroll through 3/24/2026
 2. \$10,720 payroll for balance of March 2026
 - ii. Checking - \$250,040.93
 - iii. CLASS - \$257,272.01
 - iv. EDGE - \$0.00
 - v. Total Funds - \$507,312.94
 - vi. Funds Net Payroll - \$462,352.94
- III. Discussion on Last Months' Calls-
16 medical, 8 fire and 1 UAV call for service in March



PENTWATER FIRE DEPARTMENT

486 E Park St • PO Box 1117
Pentwater, MI 49449

Phone 231.869.5987 • Fax 231.869.8511
www.pentwaterfiredepartment.com

Executive Board Meeting Agenda

Meeting Date: April 2, 2026 20:00

Meeting Location: Pentwater Fire Department

Call to Order

- I. Vote on Proposed Fleet Transaction
 - a. A motion was made by Mike Barefoot to request approval from Pentwater Township for the private sale of 341 and was seconded by Brad Van Duinen. The motion was unanimously passed by all PFD Board members.
 - b. Proposal to be submitted to Lynne Cavazos for Township review and approval.



PENTWATER FIRE DEPARTMENT

486 E Park St • PO Box 1117
Pentwater, MI 49449

Phone 231.869.5987 • Fax 231.869.8511
www.pentwaterfiredepartment.com

Monthly Meeting Agenda

Meeting Date: Wednesday, May 6, 2026 19:00
Meeting Location: Pentwater Fire Department
Call to Order

- I. Pledge of Allegiance
- II. Reading and Approval of Minutes
 - a. Minutes from 3/4/26
 - b. No April meeting was held
- III. Reports of Officers
 - a. Treasurer Brad Van Duinen
 - i. Ending Payroll - \$13,510
 - ii. Checking - \$202,148.81
 - iii. CLASS – \$ 258,065.66
 - iv. EDGE - \$0.00
 - v. Total Funds - \$460,214.47
 - vi. Funds Net Payroll - \$446,704.47
- IV. Old Business
 - a. By-Laws
 - b. New Millage Planning for November 2026 Election
 - c. ID Badges
 - d. New Equipment
 - i. Gas Meters
 - e. Paysheet and Report Completion Verification Process
 - f. New Hire
- V. New Business
- VI. Training
- VII. Discussion on Last Months' Calls-
 - a. 16 medical, 8 fire and 1 UAV call for service in March
 - b. 24 medical, 1 fire and 1 UAV call for service in April
 - i. 1 missed medical call
 - c. Discussion on best practices for prior months' calls
- VIII. Adjourn



PENTWATER FIRE DEPARTMENT

486 E Park St • PO Box 1117

Pentwater, MI 49449

Phone 231.869.5987 • Fax 231.869.8511

www.pentwaterfiredepartment.com

Officers Meeting Agenda

Meeting Date: Wednesday, May 6, 2026 19:00

Meeting Location: Pentwater Fire Department

Call to Order

Please note- the agenda for the Officer Meeting is the same as the regular monthly meeting and items are often discussed at both meetings.

- I. Pledge of Allegiance
- II. Reading and Approval of Minutes
 - a. Minutes from 3/4/26
 - b. No April meeting was held
- III. Reports of Officers
 - a. Treasurer Brad Van Duinen
 - i. Ending Payroll - \$13,510
 - ii. Checking - \$202,148.81
 - iii. CLASS – \$ 258,065.66
 - iv. EDGE - \$0.00
 - v. Total Funds - \$460,214.47
 - vi. Funds Net Payroll - \$446,704.47
- IV. Old Business
 - a. By-Laws
 - b. New Millage Planning for November 2026 Election
 - c. ID Badges
 - d. New Equipment
 - i. Gas Meters
 - e. Paysheet and Report Completion Verification Process
 - f. New Hire
- V. New Business
- VI. Training
- VII. Discussion on Last Months' Calls-
 - a. 16 medical, 8 fire and 1 UAV call for service in March
 - b. 24 medical, 1 fire and 1 UAV call for service in April
 - i. 1 missed medical call
 - c. Discussion on best practices for prior months' calls



PENTWATER FIRE DEPARTMENT

486 E Park St • PO Box 1117
Pentwater, MI 49449

Phone 231.869.5987 • Fax 231.869.8511
www.pentwaterfiredepartment.com

VIII. Adjourn



PENTWATER FIRE DEPARTMENT

486 E Park St • PO Box 1117
Pentwater, MI 49449

Phone 231.869.5987 • Fax 231.869.8511
www.pentwaterfiredepartment.com

Executive Board Meeting Minutes

Meeting Date: April 2, 2026 20:00

Meeting Location: Pentwater Fire Department

Call to Order

- I. Vote on Proposed Fleet Transaction
 - a. A motion was made by Mike Barefoot to request approval from Pentwater Township for the private sale of 341 and was seconded by Brad Van Duinen. The motion was unanimously passed by all PFD Board members.
 - b. Proposal to be submitted to Lynne Cavazos for Township review and approval.



PENTWATER FIRE DEPARTMENT

486 E Park St • PO Box 1117
Pentwater, MI 49449

Phone 231.869.5987 • Fax 231.869.8511
www.pentwaterfiredepartment.com

Monthly Meeting Minutes

Meeting Date: Wednesday, March 4, 2026 19:00

Meeting Location: Pentwater Fire Department

Call to Order

- I. Pledge of Allegiance
- II. Reading and Approval of Minutes
 - a. Minutes from 2/4/26
 - b. A motion to approve the minutes was made by Mike Barefoot and seconded by Kyle Dillingham. The motion was unanimously passed by all members present.
- III. Reports of Officers
 - a. Treasurer Brad Van Duinen
 - i. Ending Payroll - \$31,750.00
 - ii. Checking - \$122,228.50
 - iii. CLASS - \$ 256,455.45
 - iv. EDGE - \$0.00
 - v. Total Funds - \$378,683.95
 - vi. Funds Net Payroll - \$346,933.95
- IV. Old Business
 - a. By-Laws
 - i. Waiting on lawyer approval
 - b. New Millage Planning for November 2026 Election
 - c. ID Badges
 - d. New Equipment
 - i. Gas Meters to be ordered in April
 - e. New Hire
 - i. Chris McLaughlin accepted the job offer to join PFD Fire and Rescue. His start date is pending the acceptable completion of the preemployment requirement.
- V. New Business
 - a. New 3 Year Agreement for Trash Service
 - b. Paysheet and Report Completion Verification Process
 - i. Monthly audit process
 - ii. If outstanding reports from prior month the reports will need to be completed at the first meeting of month



PENTWATER FIRE DEPARTMENT

486 E Park St • PO Box 1117
Pentwater, MI 49449

Phone 231.869.5987 • Fax 231.869.8511
www.pentwaterfiredepartment.com

- iii. Investigating FirstDue options to handle payroll and truck checks to minimize reporting issues.

VI. Training

VII. Discussion on Last Months' Calls-

- a. 18 medical, 5 fire and 2 UAV calls for service in February
- b. Discussion on best practices for prior months' calls

VIII. Adjourn

- a. Meeting adjourned by Jonathan Hughart



PENTWATER FIRE DEPARTMENT

486 E Park St • PO Box 1117

Pentwater, MI 49449

Phone 231.869.5987 • Fax 231.869.8511

www.pentwaterfiredepartment.com

Officers Meeting Minutes

Meeting Date: Wednesday, March 4, 2026 19:00

Meeting Location: Pentwater Fire Department

Call to Order

Please note- the agenda for the Officer Meeting is the same as the regular monthly meeting and items are often discussed at both meetings.

- I. Pledge of Allegiance
- II. Reading and Approval of Minutes
 - a. Minutes from 2/4/26
- III. Reports of Officers
 - a. Treasurer Brad Van Duinen
 - i. Ending Payroll - \$31,750.00
 - ii. Checking - \$122,228.50
 - iii. CLASS – \$ 256,455.45
 - iv. EDGE - \$0.00
 - v. Total Funds - \$378,683.95
 - vi. Funds Net Payroll - \$346,933.95
- IV. Old Business
 - a. By-Laws
 - i. Waiting on lawyer approval
 - b. New Millage Planning for November 2026 Election
 - c. ID Badges
 - d. New Equipment
 - i. Gas Meters to be ordered in April
 - e. New Hire
 - i. Chris McLaughlin accepted the job offer to join PFD Fire and Rescue. His start date is pending the acceptable completion of the preemployment requirement.
- V. New Business
 - a. New 3 Year Agreement for Trash Service
- VI. Training
- VII. Discussion on Last Months' Calls-
 - a. 18 medical, 5 fire and 2 UAV calls for service in February



PENTWATER FIRE DEPARTMENT

486 E Park St • PO Box 1117
Pentwater, MI 49449

Phone 231.869.5987 • Fax 231.869.8511
www.pentwaterfiredepartment.com

- b. Discussion on best practices for prior months' calls

VIII. Adjourn

- a. Meeting adjourned by Jonathan Hughart



**PENTWATER TOWNSHIP
CEMETERY MONTHLY REPORT**

MONTH OF: APRIL 2026

NUMBER OF BURIALS

Traditional:

Cremains:

Columbarium:

3

FOUNDATIONS SET:

GRAVESITES SOLD:

1

COLUMBARIUMS SOLD:

1

SCATTER BRICKS SOLD:

Equipment Maintenance:

_____ (Approximate # of hours)

Grounds Care:

_____ (Approximate # of hours)

Openings/Closings:

_____ (Approximate # of hours)

Administration:

51 (Approximate # of hours)

*(i.e. Record maintenance, phone calls, emails,
Meetings with families, grave location, etc.)*

Respectfully Submitted

MAUREEN MURPHY, CLERK

Date: 05/01/2026

Pentwater Township
Deputy Supervisor, Zoning Administrator and Ordinance Enforcement Officer
Monthly Report – May 5, 2026

The following is a summary of the activities that were conducted by the Deputy Supervisor, Zoning Administrator and Ordinance Enforcement Officer for the month of April 2026.

Deputy Supervisor - I worked with the Township Supervisor, Lynne Cavazos, F&V, and/or the Township Attorney regarding:

- Completed the Michigan Infrastructure Council, Asset Management Program training.
- Responded to sewer emergencies at the Boat House lift station and 5882 W. Longbridge Rd. The alarm was active 3 times during April 2026.
- Attended the Township Board meeting of April 8.
- Requested and reviewed a proposal for Township Sewer cleaning and televising.
- Requested and reviewed a proposal for Township Sewer smoke testing.
- Responded to requests to witness storm water entering the Village System with F&V.
- Met with DTE Energy, Haydecker Contracting and the OCRC regarding the water problem on Monroe Road near the Village limits.
- Reviewed and submitted Sanitary Sewer System invoices.
- Reviewed the proposed work for Ottawattamie Drive with the Road Commission and others on-site.
- Attended a meeting at the West Michigan Shoreline Regional Development Commission in Muskegon regarding regional collaboration on infrastructure and GIS at the request of the Township Supervisor.

Code Enforcement – Initiated Zoning Compliance action regarding a dock at 5768 Longbridge Road.

Planning Commission - The Planning Commission met on April 14 to review the following:

- A. Review and approval of a Nonconforming Building/Structure (Deck) Expansion – Witt Residence at 6168 Orange St., Parcel No. 64-001-371-003-00.
- B. Review the Nordic Village Preliminary Site Plan for a proposed development just north of the old Boat House restaurant.

Zoning Board of Appeals - The Zoning Board of Appeals did not meet in April.

Zoning Permits – The following Zoning Permits were issued in March:

1. ZP 3563 was issued to Great Lakes Pet Fencing for a chain link fence at 6335 Iroquois.
2. ZP 3564 was issued to Green Shield Home for a new deck at 6818 Orange Street.
3. ZP 3565 was issued to Visscher Construction for a new 14' x 18' deck and 4-season room at 5566 W. Branch St.
4. ZP 3566 was issued to Cottage Works for a new deck at 5306 Longbridge Road
5. ZP 3567 was issued to Ken Adams for the demolition of an existing home at 6208 Longbridge Road.
6. ZP 3568 was issued to Dianna Hofmann for a 42 sq. ft. sauna at 5876 Kennys Road.

Other Comments – None.

Sincerely,

Keith J. Edwards

Pentwater Township

Deputy Supervisor, Zoning Administrator & Ordinance Enforcement Officer

PENTWATER TOWNSHIP
TRANSFER SITE MONTHLY REPORT

Month/Year: 4/2/26-5/2/26

Total Number of Visitors: 243

Total Fees Rec'd: 2526.00

<u>Site Usage</u>	<u>Village</u>	<u>Township</u>	<u>Weare</u>
Trash:	<u>35</u>	<u>51</u>	<u>23</u>
Recycling:	<u>27</u>	<u>55</u>	<u>20</u>
Both:	<u>10</u>	<u>18</u>	<u>4</u>

Yard Waste Visitors – Village: 230

Yard Waste Visitors – Township: 94

Yard Waste Visitors – Weare: 11

Submitted By: Bob

Date: 5/4/26

(ob) a

MEMORANDUM OF UNDERSTANDING

Pentwater Public Schools – Pentwater Township – Village of Pentwater

Youth Sports and Recreation Program

This Memorandum of Understanding (“MOU”) is entered into by and between:

- **Pentwater Public Schools**, a Michigan public school district (“District”),
- **Pentwater Township**, a Michigan municipal corporation (“Township”), and
- **Village of Pentwater**, a Michigan municipal corporation (“Village”).

Collectively referred to as the “**Parties.**”

1. Purpose

The purpose of this MOU is to establish a cooperative partnership among the Parties to support and operate youth sports and recreation programs serving the community and students of the Pentwater area.

The Parties agree to collaborate in order to:

- Provide organized recreational and athletic opportunities for youth
- Maintain safe and well-managed playing facilities
- Coordinate staffing, scheduling, and program administration
- Share financial support for community recreation

2. Term

This MOU shall take effect on **April 1st, 2026**, and remain in effect until **March 31, 2027**, unless terminated or renewed by mutual written agreement of the Parties.

The school will invoice both the township and the village in February of the year the invoice should be paid.

Any party may terminate this agreement with **90 days written notice** to the other Parties.

3. Financial Contribution

The **Village of Pentwater** and **Pentwater Township** agree to jointly provide funding for the recreation program.

- The Township shall contribute: **\$7,500 annually**
- The Village shall contribute: **\$7,500 annually**

Payments shall be made to **Pentwater Public Schools** by **April 1 of each program year**.

These funds shall be used to support youth recreation and athletic programming as outlined in this agreement.

4. Responsibilities of Pentwater Public Schools

Pentwater Public Schools agrees to administer and operate the youth recreation program and shall:

Program Administration

1. Register students and participants for youth sports programs.
2. Schedule games, practices, and activities.
3. Maintain program records and participant rosters.

Staffing

The District shall:

- Hire qualified **coaches**
- Hire **umpires/referees/officials**
- Hire or appoint a **Recreation Director** to oversee programming
- Recruit and coordinate volunteers

Background Checks

The District shall conduct **criminal background checks** on all:

- Coaches
- Recreation employees
- Program staff
- Volunteers working with youth participants

All staff and volunteers must comply with District safety policies.

Facility Maintenance

The District shall maintain school athletic facilities used for recreation including:

- Playing fields
- Courts
- Athletic equipment
- General playing surface maintenance

Maintenance will be performed in accordance with District standards and safety practices.

5. Responsibilities of the Township and Village

The **Pentwater Township** and **Village of Pentwater** agree to:

1. Provide financial support as described in Section 3.
2. Promote youth recreation opportunities within the community.
3. Participate in program evaluation and planning as requested.

6. Recreation Director

The District shall appoint or hire a **Recreation Director** responsible for:

- Program coordination and oversight
- League organization
- Scheduling games and practices
- Coordinating coaches and officials
- Communicating with parents and participants
- Ensuring program safety and compliance with District policies

The Recreation Director shall report to the **Pentwater Public Schools administration**.

7. Liability and Indemnification

Participants in recreation programs will be required to sign a **Release of Liability and Participation Waiver** prior to participation.

8. Non-Discrimination

All programs administered under this MOU shall comply with all applicable federal and state non-discrimination laws and policies.

9. Amendments

This MOU may be amended only by **written agreement signed by all Parties.**

10. Signatures

Pentwater Public Schools

Name: _____
Title: _____
Signature: _____
Date: _____

Pentwater Township

Name: _____
Title: _____
Signature: _____
Date: _____

Village of Pentwater

Name: _____
Title: _____
Signature: _____
Date: _____

ob (b)



PENTWATER PUBLIC SCHOOLS



Pentwater Public Schools
600 E. Park St.
Pentwater, MI 49449

(231) 869-4100 ex. 213
Craig Barter, Superintendent

(231) 869-4535 Fax
www.pentwater.k12.mi.us

Invoice

Service Date: 3/26/26

Bill To:

Pentwater Township
500 N. Hancock
PO Box 512
Pentwater, MI 49449

Date	Your Order #	Our Order #	Sales Rep.	FOB	Ship Via	Terms	Tax ID
3/26/26							

Quantity	Item	Units	Description	Discount %	Taxable	Unit Price	Total
			Pentwater Township Recreation Plan Fees 5/1/26—4/30/27				\$7,500
Subtotal							\$7,500
Tax							N/A
Shipping							N/A
Misc.							N/A
Balance Due							\$7,500

Pay to the Order of: **PENTWATER PUBLIC SCHOOLS**
Attn: Toni Glover
600 E. Park St.
Pentwater, MI 49449

nb(a)

Resolution

To be used by governmental units in connection with applications to construct, operate, use and/or maintain within the right-of-way, or to close a county road.

(NOTE: Please use this form when submitting a Permit Resolution)

RESOLVED, that the COVE is hereby authorized to make
(Private Organization)
Application to the Oceana County Road Commission on behalf of the City/Village/Township
of Pentwater, in the County of Oceana, Michigan for the necessary permit(s)
(Name of Municipality)
to: Business 31 (Pere Marquette Hwy) from
Hancock St. to the Entrance of Duna Vista
subdivision (Saturday, August 1, 2026)

within the right-of-way of county roads Business 31 North,
and that the City/Village/Township of Pentwater, in the county of Oceana,
(Name of Municipality)
Michigan supports the requested activity.

I hereby certify that the foregoing is a true copy of a resolution adopted by the
City/Village/ Township of _____, at a _____ meeting held on the
(Name of Municipality) (Regular, special)
_____ day of _____ A.D. 20__.

Signed _____
Title _____

nb (b)

Village of Pentwater

INVOICE

Discover
PENTWATER
STAY FOR A DAY, A WEEK, A LIFE

65 S. Hancock Street
P.O. Box 622
Pentwater, MI 49449-0622

(231) 869-8301 FAX (231) 869-5120
Website: www.pentwatervillage.org

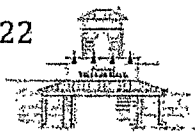

Date:	04/15/2026
Invoice #	20260415

TO: PENTWATER TOWNSHIP
PO BOX 512
PENTWATER, MI 49449

ITEM	DESCRIPTION	AMOUNT
	2026-2027 Park Place Access Agreement	7500.00
TOTAL		7500.00

Make check payable to:
Village of Pentwater
PO Box 622
Pentwater, MI 49449-0622

Fire Truck

(nb(c))

Maureen Murphy

From: Brad Van Duinen <bradley.vanduinen@gmail.com>
Sent: Tuesday, April 7, 2026 5:40 PM
To: Lynne Cavazos; Maureen Murphy; Lynne Cavazos; mbieri; Jonathan Hughart; michael barefoot
Subject: Pentwater FD Village & Township Documents
Attachments: 2026_04 PFD Meeting Package.pdf

There was no business meeting for the month of April with the next meeting scheduled for May 6, 2026. There was a PFD Executive Board meeting as noted in the attached packet. I apologize for the delay in the sending of the packet.

@Lynne Cavazos we are seeking the approval of the Township to sell 341. If this can't be brought forward in tomorrow's meeting please add for the May meeting. For any further details or clarification please contact Jonathan Hughart. Thank you.

Sincerely,
Brad Van Duinen
PFD Secretary / Treasurer

nh(c)

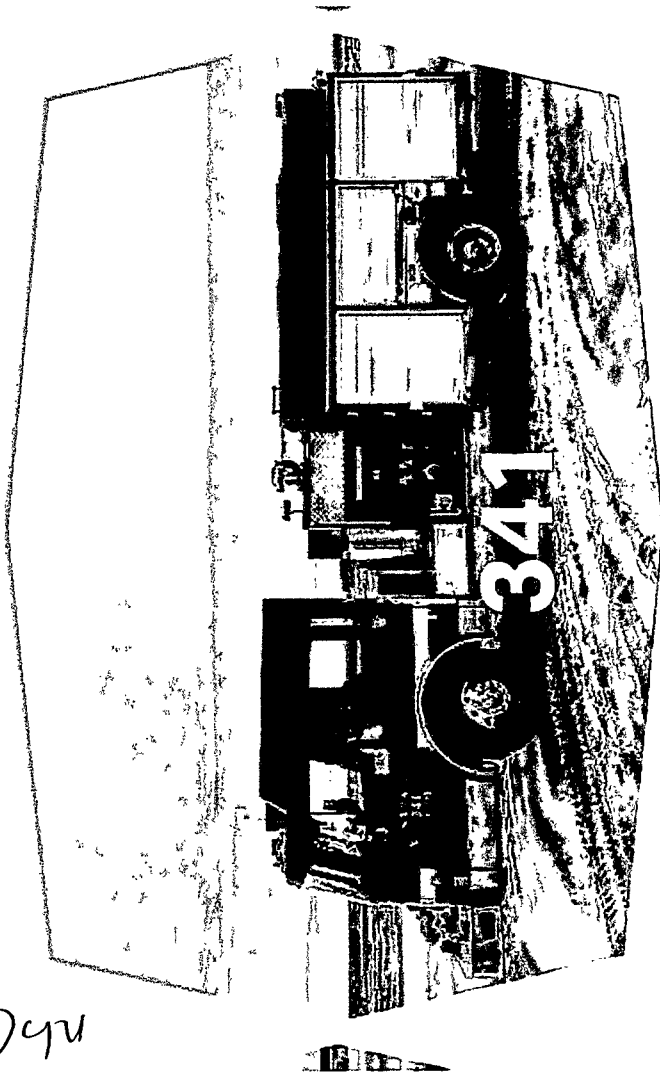

Secondary Class A Pumper with 1500 gal/min pump with a 1000 gal Water Tank.

nb (d)

Site Accessibility Evaluation Pentwater Township Hall



500 N Hancock St

Pentwater, MI 49449

Inspection Date: 02/23/2026

Inspectors: Marquis Childers
Kim Frost

Prepared By



Report Date: 03/27/2026

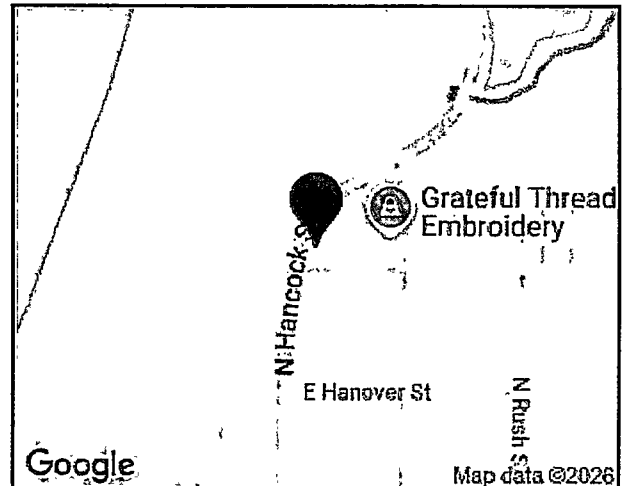

03/27/2026

Dear Pentwater Township Board,

Thank you for the opportunity to perform an accessibility evaluation for the Pentwater Township Hall located at 500 N Hancock St, Pentwater, MI 49449. The facility was inspected on 02/23/2026.

As a local government, Pentwater Township is covered by Section II of the Americans with Disabilities Act, and is therefore required to provide program access, meaning that individuals with disabilities are not excluded from any program, service, or activity provided by the government because existing buildings and facilities are inaccessible. State and local governments must look at their programs, services and activities in their entirety to ensure that they are accessible.

Overall, the Hall was exceptionally accessible, with exceptions noted in the following report. We commend the Township on its commitment to inclusion of all residents, and on the steps which have already been taken to provide accessible design that meets or exceeds Americans With Disability Act Standards.

These include, but are not limited to:

- Signs with braille and raised text on all interior doors;
- Ramps at both north and south entrances;
- Employee hallways that exceed the minimum required width;
- A drinking fountain with easy knee and toe clearance;
- Accommodations thought out for residents who may need additional assistance.

Throughout this report, we refer to the 2010 Americans With Disability Act Standards (ADAS), which can be found at <https://www.ada.gov/law-and-regs/design-standards/2010-stds/>. Numbers following "ADAS" refer to chapter and section number, such that ADAS 502.2 would refer to Chapter 5, section 502: Parking Spaces, subsection 2: Vehicle Spaces.

We recommend that all identified barriers in this evaluation which are able to be eliminated with minimal difficulty or expense be removed as soon as possible, with other barriers being removed as funding becomes available. A barrier removal plan should be developed to assist in planning. While it is your responsibility to prioritize and remove these barriers, we have provided some brief guidelines, as well as an estimated timeline worksheet, to help.

Priority 1 – High: Should be completed immediately. (Includes; Findings that have little or no cost, were in violation of the codes at the time of construction, or pose an imminent safety threat)

Priority 2 – Important: Should be completed as soon as possible. (Includes; Findings that would remove barriers to the greatest number of people to your goods and services)

Priority 3 – Moderate: Should be completed as soon as possible, but there may be other items that will provide greater access to persons with disabilities. (Includes; Findings that have a high financial impact on the entity in relationship to the degree of access provided)

Priority 4 – Low: Should be completed as soon as possible due to being a technical violation but may not result in providing greater access to persons with disabilities. (Includes Findings that are technically violations but provide a moderate to low increase in accessibility compared to the financial impact on the entity)

Periodic maintenance to ensure continued accessibility is essential in providing a safe and usable environment. Parking lot markings, signage, door opening pressures, and maintaining clear floor space at doors and other elements and fixtures available to the public should be part of an ongoing maintenance schedule.

If you have any questions regarding this report or would like to schedule a meeting with myself and your architect, attorney, or contractor, please feel free to contact me.

Disability Network West Michigan can provide guidance and consultation related to accessibility improvements. Additional support may include plan review and general accessibility recommendations. Coordination with third party professionals may be recommended for construction monitoring, ownership representation, and verification of completed work prior to acceptance.

Sincerely,

Marquis Childers

Sincerely,

Marquis Childers
Marquis Childers

Table of Contents

Findings 5

South Entrance 5

 South Entrance Ramp..... 5

Accessible Parking 7

 Accessible Parking Sign..... 7

Exterior & Interior Ballot/ Payment Box 9

 Ballot/Payment Box..... 9

 Ballot Box.....10

 Payment Box.....11

Public Area 12

 Interior Route.....12

Accessible Restrooms..... 13

 Paper Towel Dispenser.....13

Service Counters 14

 Service Counters are above maximum reach range14

Information Table..... 15

 Information table is too deep for side reach15

Temperature Controls 16

 Temperature Controls.....16

Estimated Time-Line for Barrier Removal.....17

South Entrance: South Entrance Ramp

Finding: 1

The handrail does not extend past the ramp.

Handrails must be between 34 inches and 38 inches above the ramp surface and must extend beyond the top and bottom of the ramp run 12 inches horizontally. The 12 inches horizontal extensions must not include the radius at the top end of round handrails. Extensions shall return to a wall, guard, or the landing surface, or shall be continuous to the handrail of an adjacent ramp run.

Citation:	As Built:	Budgeting Range:
2010 ADAS Section: 505.10.1	Handrails extend approximately 4 inches beyond the end of the ramp.	\$250 - \$1,500.00

Recommendation:

Provide handrails extensions at least 12" beyond the end of the ramp surface.

Barrier Priority:

Low (4): Should be completed as soon as possible due to being a technical violation, but may not result in providing greater access to persons with disabilities. (Includes; Findings that are technically violations but provide a moderate to low increase in accessibility compared to the financial impact on the entity)

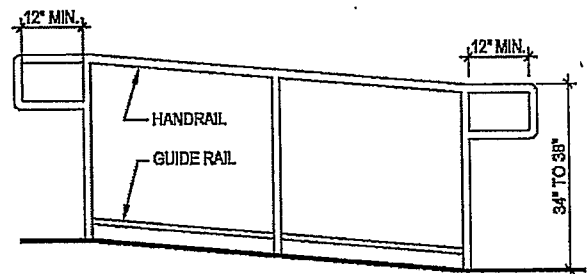
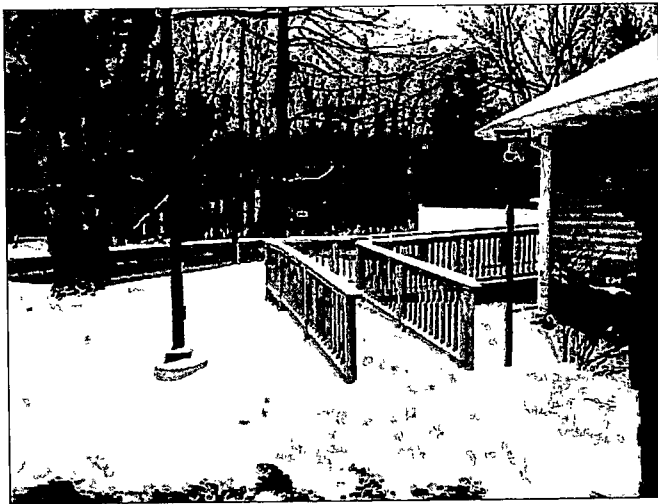

Accessible Parking: Accessible Parking Sign

Finding: 2

There are no marked van accessible parking spaces.

1 in every 6, minimum of one, required accessible spaces must be a van accessible space.

Citation:

2010 ADAS Section: 208.2,
208.2.4

As Built:

Stall and access aisle meet standards for van access. The sign is mounted to the side of the space and does not include "van accessible"

Budgeting Range:

\$100 - \$500.00

Recommendation:

Mount a new sign which includes the international sign for accessibility and states "van accessible" in front of the accessible parking space with the bottom of the sign at least 60" above the ground.

Barrier Priority:

Moderate (3): Should be completed as soon as possible, but there may be other items that will provide greater access to persons with disabilities. (Includes; Findings that have a high financial impact on the entity in relationship to the degree of access provided)

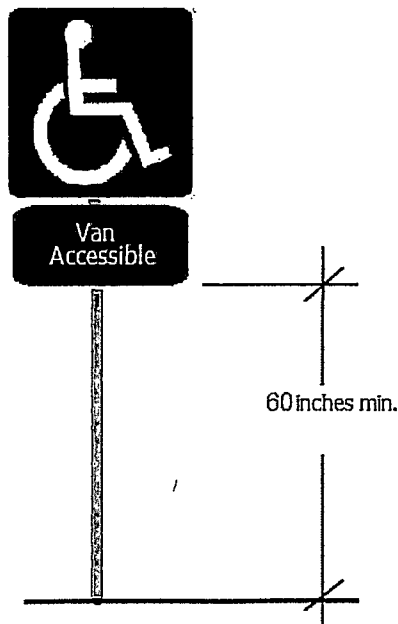

Accessible Parking: Accessible Parking Sign

Finding: 3

The parking sign is mounted to the side of the parking stall.

parking space identification signs shall include the International Symbol of Accessibility. Signs identifying van parking spaces shall contain the designation "van accessible". Signs shall be 60 inches minimum above the finish floor or ground surface measured to the bottom of sign.

Each accessible parking space should be marked with its own sign which is clearly visible when a vehicle is parked in the parking stall. Signs should be located directly in front of the parking stall to ensure that the access aisle and accessible routes remain clear

Citation:

2010 ADAS Section: 502.6

As Built:

See finding 2

Recommendation:

Refer to Finding 2

Barrier Priority:

Refer to Finding 2

Exterior & Interior Ballot/ Payment Box : Ballet/Payment Box

Finding: 4

The ballot and payment boxes are not accessible because there is not adequate clear floor space for an approach.

The clear floor or ground space shall be 30 inches minimum by 48 inches minimum.

Citation:

2010 ADAS Section: 305.3

As Built:

At the time of evaluation, shovels were stored below the exterior ballot & payment boxes.

Recommendation:

Make sure that shovels and other items are stored outside of the required clear floor space.

Barrier Priority:

High (1): Should be completed immediately. (Includes; Findings that have little or no cost, were in violation of the codes at the time of construction, or pose an imminent safety threat)

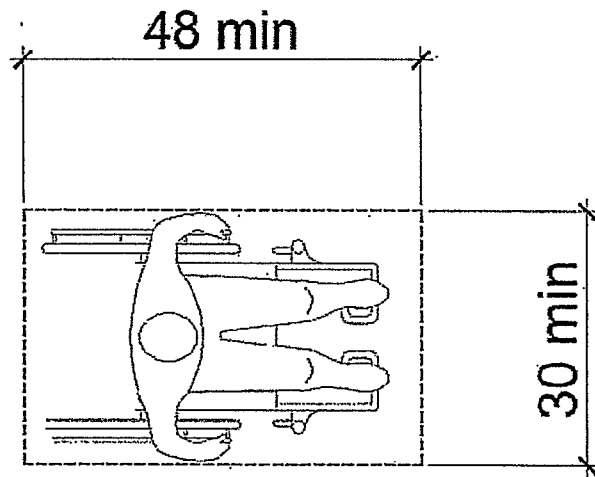

Exterior & Interior Ballot/ Payment Box : Ballot Box

Finding: 5

The opening to the absentee ballot box is positioned too high for either side or front approach.

Citation:	As Built:	Budgeting Range:
2010 ADAS Section: 308.2.2	The heights of the ballot slot is 54 inches	\$300 - \$1,500.00

Recommendation:

Move absentee ballot box down so that the payment slot is no more than 48" above the decking surface.

Barrier Priority:

High (1): Should be completed immediately. (Includes; Findings that have little or no cost, were in violation of the codes at the time of construction, or pose an imminent safety threat)

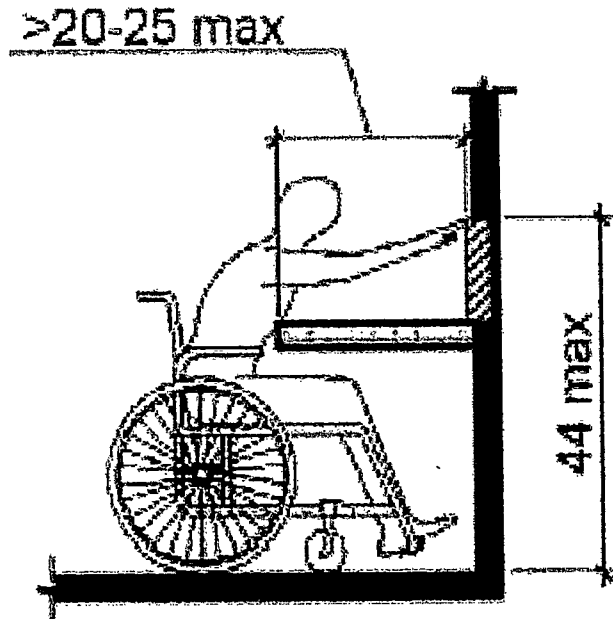

Exterior & Interior Ballot/ Payment Box : Payment Box

Finding: 6

The opening to the exterior payment box is positioned too high for either side or front approach.

Where a high forward reach is over an obstruction, the clear floor space shall extend beneath the element for a distance not less than the reach depth over the obstruction. Where the reach depth exceeds 20 inches, the high forward reach shall be 44 inches maximum and the reach depth shall be 25 inches maximum.

Citation:	As Built:	Budgeting Range:
2010 ADAS Section: 308.2.2	The height of the payment box exceeds 60" inches; there is an interior payment box which meets standards.	\$150 - \$1,500.00

Recommendation:

Refer to finding 5

Barrier Priority:

Moderate (3): Should be completed as soon as possible, but there may be other items that will provide greater access to persons with disabilities. (Includes; Findings that have a high financial impact on the entity in relationship to the degree of access provided)

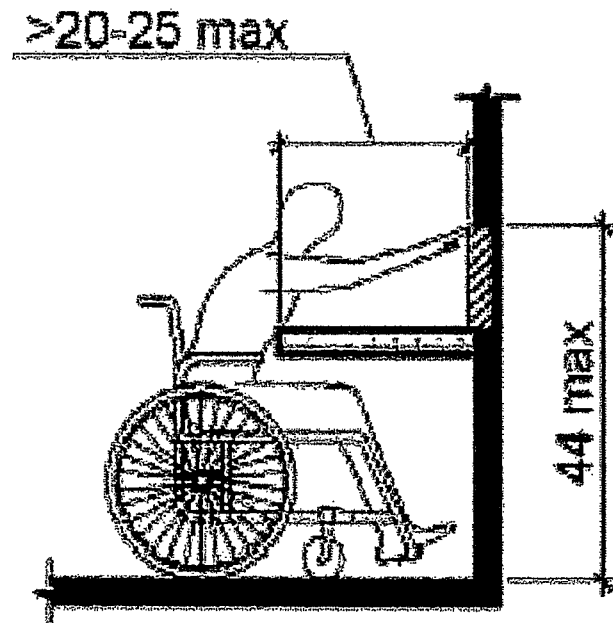

Public Area: Interior Route

Finding: 7

The route of travel does not provide a minimum width of 36 inches.

The clear width of walking surface shall be 36 inches (915mm) minimum

Citation:

2010 ADAS Section: 403.5.1

As Built:

The route from the north and south entrances as it narrows between the monitor and conference table, can narrow to less than 36 inches when chairs are pulled out.

Recommendation:

Store chairs from the monitor side of the conference tables in the center of tables unless in use.

Barrier Priority:

High (1): Should be completed immediately. (Includes; Findings that have little or no cost, were in violation of the codes at the time of construction, or pose an imminent safety threat)

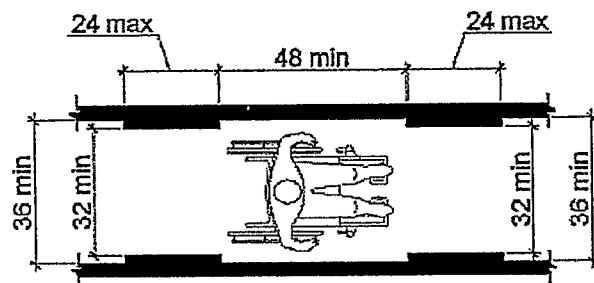

Accessible Restrooms: Paper Towel Dispenser

Finding: 8

The element is not accessible because there is not adequate clear floor space for an approach.

The clear floor or ground space shall be 30 inches minimum by 48 inches minimum.

Citation:

2010 ADAS Section: 305.3

As Built:

At the time of evaluation, there was a vacuum cleaner charging beneath the towel dispenser

Recommendation:

Move vacuum cleaner so that there is at least 30 inches of clear floor space in front of the towel dispenser

Barrier Priority:

High (1): Should be completed immediately. (Includes; Findings that have little or no cost, were in violation of the codes at the time of construction, or pose an imminent safety threat)

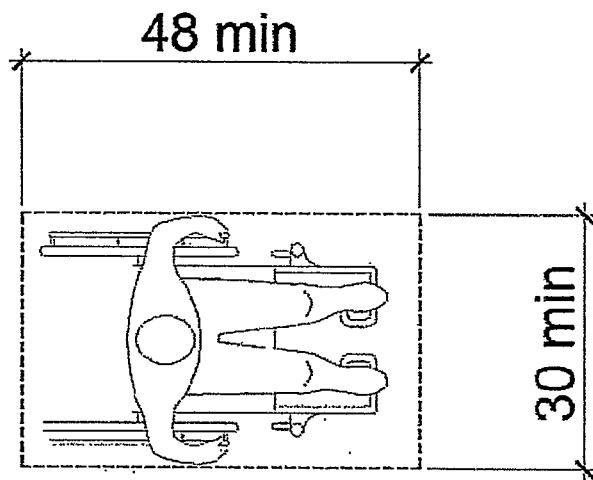
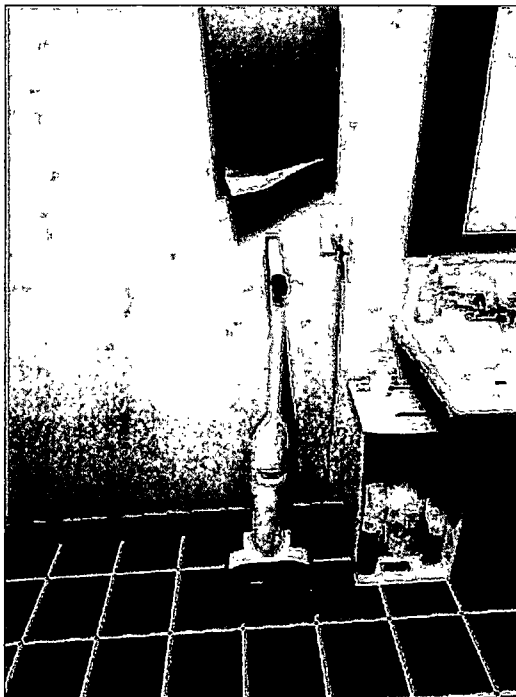

Service Counters: Service Counters are above maximum reach range

Finding: 9

The element is not accessible because service counters are positioned too high for either side or front approach.

Where a clear floor or ground space allows a parallel approach.

Where a forward reach is unobstructed, the high forward reach shall be 48" maximum and the low forward reach shall be 15 inches minimum above the finished floor or ground

Citation:

2010 ADAS Section: 305.3

As Built:

N/A

Budgeting Range:

\$150 - \$1,500.00

Recommendation:

Lower all service counters to a maximum of 48 inches

Barrier Priority:

Important (2): Should be completed as soon as possible. (Includes; Findings that would remove barriers to the greatest number of people to your goods and services)

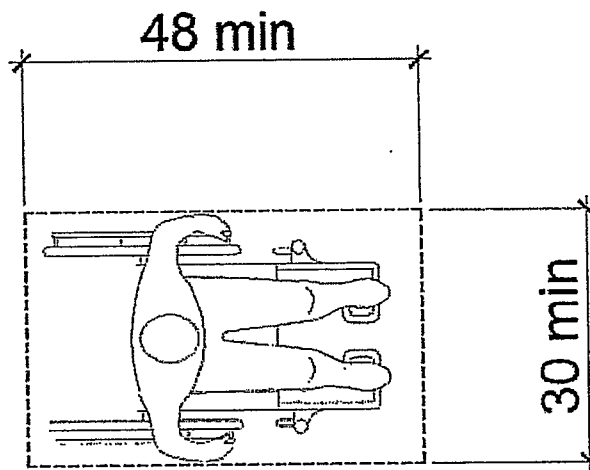

Information Table: Information table is too deep for side reach

Finding: 10

The element could be made more accessible by reducing the needed reach

Where a high forward reach is over an obstruction, the clear floor space shall extend beneath the element for a distance not less than the required reach depth over the obstruction. The high forward reach shall reach shall be 48" (1220mm) maximum where the reach depth is 20 inches (510m) maximum. Where the reach depth exceeds 20inches (510mm), the high forward reach shall be 44 inches (1120mm) maximum and the reach depth shall be 25 inches (635mm) maximum

Where a clear floor or ground space allows a parellel approach to an element and the side reach is over an obstruction, the height of the obstruction shall be 34 inches (865mm) maximum and the depth of the obstruction shall be 24 inches (610mm) maximum. The high side reach shall be 48 inches (1220mm) maximum for a reach depth of 10 inches (225mm) maximum. Where the reach depth exceeds 10 inches (225mm), the high side reach shall be 46 inches (1170mm) maximum for a reach depth of 24 inches (610mm) maximum

Citation:

2010 ADAS Section: 305.3

As Built:

Meet ADA Standards

Budgeting Range:

\$50 - \$100.00

Recommendation:

Use narrower information

Barrier Priority:

Important (2): Should be completed as soon as possible. (Includes; Findings that would remove barriers to the greatest number of people to your goods and services)

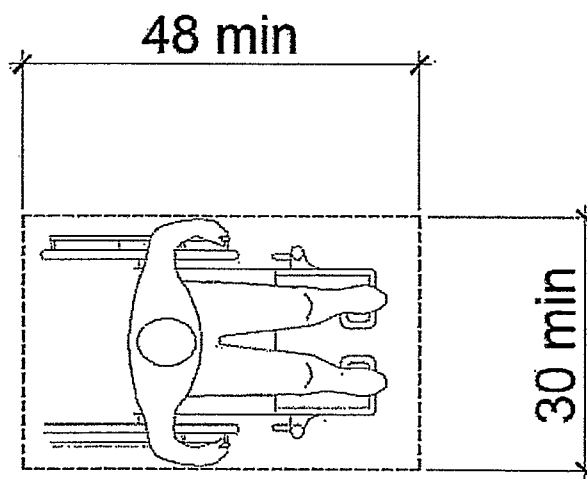

Finding 2056 Main Photo

Temperature Controls

Finding: 11

The temperature control is positioned too high for either a side or front approach.

Where a clear floor or ground space allows a parallel approach to an element and the side reach is unobstructed, the high side reach shall be 48 inches maximum and the low side reach shall be 15 inches minimum above the finish floor or ground.

Where a forward reach is unobstructed, the high forward reach shall be 48 inches maximum and the low forward reach shall be 15 inches minimum above the finish floor or ground.

Citation:	As Built:	Budgeting Range:
2010 ADAS Section: 308.1	The climate controls near the drinking fountain are 60 inches or more above the floor	\$500 - \$2,000.00

Recommendation:

Move temperature controls down so that they are no more than 60" above ground

Barrier Priority:

Low (4): Should be completed as soon as possible due to being a technical violation, but may not result in providing greater access to persons with disabilities. (Includes; Findings that are technically violations but provide a moderate to low increase in accessibility compared to the financial impact on the entity)

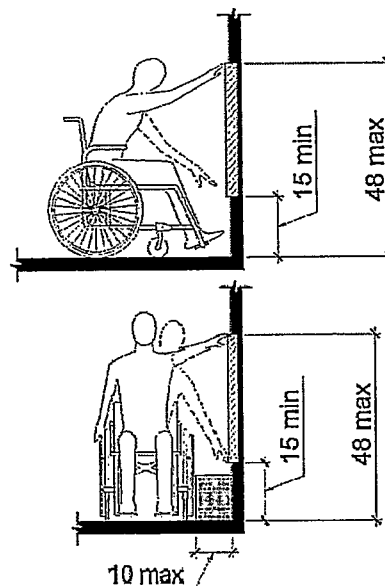

Estimated Time-Line for Finding Removal
(Please complete and return page/s to be inserted in report)

South Entrance: South Entrance Ramp	Est. Remediation Date
Finding 1 The handrail does not extend past the ramp. Handrails must be	____/____/____
Accessible Parking: Accessible Parking Sign	Est. Remediation Date
Finding 2 There are no marked van accessible parking spaces. 1 in every	____/____/____
Finding 3 The parking sign is mounted to the side of the parking stall.	____/____/____
Exterior & Interior Ballot/ Payment Box : Ballet/Payment Box	Est. Remediation Date
Finding 4 The ballot and payment boxes are not accessible because there is	____/____/____
Exterior & Interior Ballot/ Payment Box : Ballot Box	Est. Remediation Date
Finding 5 The opening to the absentee ballot box is positioned too high	____/____/____
Exterior & Interior Ballot/ Payment Box : Payment Box	Est. Remediation Date
Finding 6 The opening to the exterior payment box is positioned too high	____/____/____
Public Area: Interior Route	Est. Remediation Date
Finding 7 The route of travel does not provide a minimum width of 36	____/____/____
Accessible Restrooms: Paper Towel Dispenser	Est. Remediation Date
Finding 8 The element is not accessible because there is not adequate	____/____/____
Service Counters: Service Counters are above maximum reach range	Est. Remediation Date
Finding 9 The element is not accessible because service counters are	____/____/____
Information Table: Information table is too deep for side reach	Est. Remediation Date
Finding 10 The element could be made more accessible by reducing the needed	____/____/____
Temperature Controls	Est. Remediation Date
Finding 11 The temperature control is positioned too high for either a side	____/____/____

Nb (e)

MAY 2023

PENTWATER TOWNSHIP PURCHASING & PROCUREMENT POLICY

Policy 2016-01

PURPOSE:

The purpose of this policy is to provide purchasing guidelines to assure that Pentwater Township maintains lawful and ethical methods in the procurement of supplies, materials, equipment, contracted services and construction projects for the Township.

AUTHORITY:

The Township Supervisor shall be responsible for the administration of the procurement system of the Township. The Township Supervisor or his/her designee shall be the Township purchasing agent.

GENERAL PURCHASING POLICIES:

A. Definition and Scope of Procurement

Procurement activity, as herein used, shall mean any action taken by the Township acting as Buyer for the purpose of obtaining materials, supplies, services and public improvements (hereafter goods and services) from a Vendor acting as Seller, whether by purchase, rent, lease, lease-purchase, or other similar methods of acquisition as may be used by the Township.

B. Rule Against Subdivision

No purchase shall be subdivided for the purpose of circumventing the dollar value limitations imposed by this policy, policy or any guidelines established by the Township Supervisor...

C. Purchases or Contracts Under ~~\$2,000~~ Up to \$5,000

Any expenditure for routine goods and services, the cost of which is ~~less~~ no greater than \$25,000, may be made by the Township Supervisor with the concurrence of the Township Clerk.

~~D. Purchases or Contracts Between \$2,000 – \$5,000~~

~~Purchases from \$2,000 – \$5,000 shall be based upon the solicitation of no less than three (3) written or internet price quotations when practical and feasible to do so, and shall be made from the lowest priced vendor unless good cause exists not to do so. Factors, including, but not limited to, product quality, serviceability, delivery, emergencies, vendor history, vendor performance, existing contracts and other considerations or a similar kind normally relevant to the exercise of good business judgment shall constitute sufficient and good cause on which to base such decisions,~~

~~with Board approval.~~

E. Purchases or Contracts of More Than \$5,000

Any expenditure for goods or services, the cost of which is more than \$5,000 or more within one fiscal year shall be made via a formal bidding process after Board approval.

F. Procurement of Professional Services

The procurement of certain services where technical expertise or knowledge of a specialized field are critical to the performance of that service including, but not limited to, attorneys, engineers, planning consultants, architects, accountants and other similar professionals, shall not require bidding. The following regulations shall apply:

1. The Board shall be empowered to appoint the Township Attorney and other professional consultants.
2. While competitive bids are not required, the Board shall review and ~~approval~~ approve all professional appointments or engagements in excess of \$25,000.

G. Procurement in Cases of Emergency

Notwithstanding any other provisions of this Policy, the Township Supervisor and the Clerk and Treasurer, may make or authorize others to make emergency procurements when there exists a threat to public health, welfare, or safety conditions, provided such emergency procurements shall be made with such competition as is practicable under the circumstances without complying with the bidding procedures. If an emergency requires a decision and another board member is not available, the Township Supervisor shall make the decision. The Township Supervisor shall report the details of any emergency procurement/purchase to the Township Board at its next regular meeting.

H. Expenditures Not Requiring Bidding or Board Approval

Contracts for purchases that are reasonably necessary for the functioning of the Township on a day to day basis, such as, but not limited to, necessary supplies for the operation of the respective office, may be purchased by the respective Elected Officer or employee on an "as needed" basis. It is assumed that all or most of such purchases have been previously budgeted and/or appropriated in the annual operating budget.

The purpose of this section of the Township's policy is to insure the smooth and uninterrupted functioning of the Township government and to keep a reasonable amount of supplies and/or inventory to insure the same. Further, as to the "purchase of services", there may be, from time to time, a need to incur the expense of repairs to Township buildings/equipment. As long as the contract for such services does not exceed \$25,000, the Township Supervisor has the authority to enter into such agreements.

I. Local Vendors

Where possible, the Township shall utilize local vendors. "Local" means either within Pentwater Township or if not available or provided within the Township, then in the State of Michigan.

STANDARDS OF CONDUCT:

Recognizing that Township purchases involve the use of public funds, the following standards shall apply to all purchases made by the Township.

A. All vendors, current and prospective, shall be treated equitably. Procurement decisions shall be based upon price, quality, delivery, references, and recommendation by Township consultants, written standards, previous service and other relevant factors promoting the best interest of the Township.

B. Employees and Township Board members shall be prohibited from furnishing to any prospective bidder, information that would give any vendor an unfair advantage over other prospective vendors.

C. No employee or Township Board member may participate in any purchase or procurement if the employee, elected official or immediate family member of either, has a financial interest pertaining to the procurement, including but not limited to, receiving anything of value from the vendor as a result of the purchase or award of a contract to such vendor by the Township.

AMENDMENTS TO PURCHASING POLICY:

Any amendments to this Purchasing and Procurement Policy shall be reviewed and approved by the Township Board. The Township Board shall review the monetary limitations governing the purchasing policies and procedures contained in the Policy as needed.

Ayes: ~~Smith, Siska, Ruggles, Flynn, Holub~~

Nays: None

Absent: None

I **HEREBY CERTIFY** that the above Policy was duly adopted by the Pentwater Township Board of Trustees, Oceana County, State of Michigan, at a regular meeting held in the Pentwater Community Hall on October 12, 2016.

~~Dean Holub~~ Maureen Murphy, Clerk

Date _____

nb (F)

MEMORANDUM

To: Pentwater Township Board

From: Glenn Beavis

Date: May 6, 2026

Subject: **Needed Cemetery Fence Repairs**

The 420' of split rail fence along the backside of Block 20 is in serious need of repair/replacement. Additionally, the white vinyl fencing gates that surround the Rid-O-Rust stations at Block 20 and Block 15 need repair. Photos of the areas in question are attached.

I reached out to three vendors and accompanied them to the site. All three presented quotes that were remarkably close in price to one another, and all three are reputable contractors in my opinion. The third vendor noted gate misalignment and the lack of a gate backstop at Block 15 that I had not previously noted and so did not request quotes from the other two vendors. The quotes include complete removal and replacement of the 420' fence, including disposal of the old materials.

Regarding the two vinyl fenced enclosures, all three vendors noted improper attachment of gates to their respective posts at Block 20, and the lack of gate drop rods to prevent over-extension into the enclosed area. This has led to repeated failures of the gates at Block 20 and could result in more costly future repairs to the gates at Block 15 if not addressed soon.

While all three vendors are fully capable and competitively priced, my recommendation is to move forward with Straight Line Fencing and to have them repair the vinyl gates at Block 15 while there. Their quote is slightly less than the competitors for equivalent work, and they are the ones who noted the need for repair of the vinyl gates at Block 15 (quoted separately). Great Lakes Fencing's quote has expired and requires requote. I am neutral on Affordable Fence. See summary below.

Glenn Beavis
Deputy Clerk

	Main Fence	Rid-O-Rust Gate	2nd Vinyl Gate	Total	Comments
Great Lakes Pet Fencing:	\$7,778	\$190	n/a	\$7,968	- 10 day acceptance, EXPIRED - Informal offer to replace 2 broken posts at other locations using best of removed fencing - Donated all material & labor costs for Community Garden several years ago - No Michigan Sales Tax giveback
Affordable Fence:	\$6,978	\$980	n/a	\$7,958	- Offer to replace 2 broken posts at other locations using best of removed fencing - No Michigan Sales Tax giveback
Straight Line Fence:	\$7,000	\$600	\$550	\$8,150	- Gates near Block 15 mis-aligned & needs drop rod stop. - Would also include drop rod stop at Rid-O-Rust gate. (not mentioned by other vendors) - Local owner with 20 crews - No Michigan Sales Tax giveback
Note 1: All quotes include removal and disposal of existing fencing					
Note 2: All quotes carry caveats for additional charges if unexpected issues arise					
Note 3: All quotes set posts without use of concrete as requested					
Note 4: Gate posts for vinyl fencing were improperly constructed & no drop rod installed to prevent over-extension. This led to failure.					



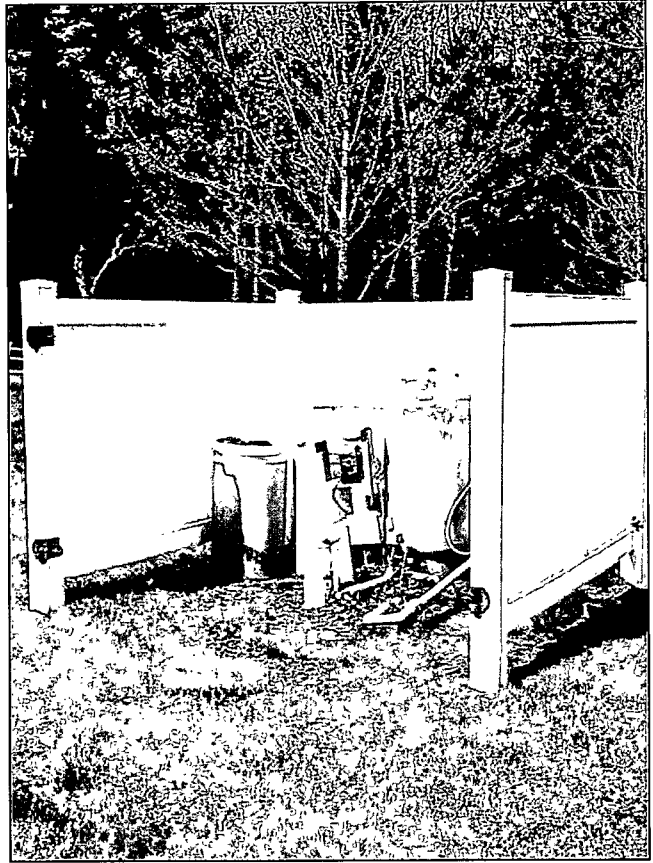

nb(g)

MEMORANDUM

To: Pentwater Township Board of Trustees

From: Keith Edwards, Deputy Supervisor

Date: May 5, 2026

Subject: Request to clean and televise the Township North gravity sewer

The 2023 Fleis & Vandenbrink Sanitary Sewer Evaluation report recommends cleaning and televising all gravity sanitary sewer to inspect the pipes for cracks, surface and groundwater infiltration and any illicit connections.

Enclosed, please find a proposal from Fleis & Vandenbrink Operations for completing this work. Please consider approving the work with funds from the Sewer Fund, Department 592.



May 5, 2026

Via email: zoningadministrator@pentwatertownshipmi.gov

Keith Edwards, Deputy Supervisor
Zoning Administrator and Ordinance Enforcement Officer
Pentwater Township
500 N. Hancock Street
PO Box 512
Pentwater, MI 49449

Dear Mr. Edwards,

F&V Operations and Resource Management, Inc. (FVOP), appreciates the opportunity to submit this proposal for sewer cleaning and televising services for Pentwater Township. We will work together with the engineering team for an updated review of the gravity sewer system. We have enjoyed working with you over the last couple of years.

SCOPE OF SERVICES

FVOP proposes to clean and televise the gravity sanitary sewer lines within Pentwater Township as well as clean all three lift stations. This task will be completed using a combination of a vactor truck and main line televising truck. This proposal does not include services within the boundaries of the Village of Pentwater.

Should one end of the pipe not be passable due to blockage, we will set up and attempt to clean and or televise from the opposite end. If that end is also impassable, the township will be notified, and an additional proposal will be presented.

Televising will be completed post-cleaning; televising will include digital videos and reports of our findings. Structural issues encountered will be identified and reported to Pentwater Township.

When encountering heavy cleaning including root cutting, millings, or large amounts of debris, we will notify Pentwater Township of such problem areas to determine next steps and projected increases to the budget. Routine cleaning is up to two passes in each section. If additional passes are necessary, that location will then be identified as heavy cleaning and an additional proposal or written approval to continue working with estimated expenses will be provided at that time.

BUDGET

We recommend an estimated budget for the base scope of services of \$435 per hour for two operations specialists to clean approximately 8,000 feet of sanitary sewer and three lift stations, and televise approximately 8,000 lineal feet of 8-inch, 10-inch, and a few unknown sanitary sewers. An estimated budget of \$28,000 is recommended to complete these services.

Subcontracted services and materials will be invoiced at 1.15. Pentwater Township will be directly billed from Village of Pentwater for water usage. FVOP will dispose of debris from cleaning and lift stations at the Muskegon County Wastewater Facility.

2960 Lucerne Drive SE
Grand Rapids, MI 49546
P: 616.588.2900
www.fv-operations.com

SCHEDULE

FVOP is prepared to begin this work within 60 days upon receiving your written approval of this proposal.

This proposal is valid until October 31, 2026, at which time FVOP reserves the right to adjust the hourly rate based on wage and equipment changes annually. Either party may terminate with or without cause with a 30-day written notice.

If you concur with our Scope of Services, Budget, and Terms and Conditions, you may authorize us to begin work by signing the Work Authorization herein and returning it me via email to agreements@fv-operations.com, or via U.S. Mail.

We thank you for this opportunity and we look forward to assisting you with this project. If you have any questions regarding this proposal or any FVOP services, please contact me at 616.588.1919.

Sincerely,

FVOP OPERATIONS AND RESOURCE MANAGEMENT, INC.

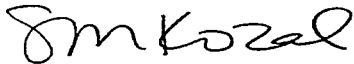

Stephanie Kozal
Grand Rapids Area Manager | Associate

WORK AUTHORIZATION

F&V Operations and Resource Management, Inc. (FVOP), is hereby authorized to perform additional Services detailed in this letter dated May 5, 2026. Under the terms and conditions provided in our existing Professional Services Authorization dated April 12, 2023.

Signature

Date

(Please print name and title)

*Please send completed Additional Work Authorization to
F&V Operations and Resource Management, Inc.,
via email to agreements@fv-operations.com,
or US Mail to 2960 Lucerne Drive SE, Grand Rapids, MI 49546.*

nbCh)

MEMORANDUM

To: Pentwater Township Board of Trustees

From: Keith Edwards, Deputy Supervisor

Date: May 5, 2026

Subject: Request to smoke test the Township North gravity sewer

During a rain event and the week of April 6, 2026, the Township North System sanitary Sewer system exceeded the allowable flow of 8,000 gallons. For a total of 8,439 gallons. This will result in a surcharge showing up on the Township's next quarterly bill from the Village that we will receive after June 30, 2026.

In an effort to begin tracking down potential inflow and infiltration of groundwater and / or stormwater into the Township North System, our engineers at Fleis & Vandenbrink recommend smoke testing the gravity sewer sometime in mid-summer.

Enclosed, please find a proposal from Fleis & Vandenbrink Engineers for completing this work. Please consider approving the work with funds from the Sewer Fund, Department 592.

May 5, 2026

Via email: zoningadministrator@pentwatertownshipmi.gov

Keith Edwards
Pentwater Township
500 N. Hancock Street
PO Box 512
Pentwater, MI 49449

RE: Smoke Testing Proposal

Dear Keith:

As discussed, we have prepared this proposal to conduct smoke testing of gravity sewer segments within the Township North sewer system. We have also included an optional supplemental fee should the Township wish to take advantage of economies of scale by extending smoke testing to the Apache Hills section. Both areas are illustrated in the maps below for reference.



Township North

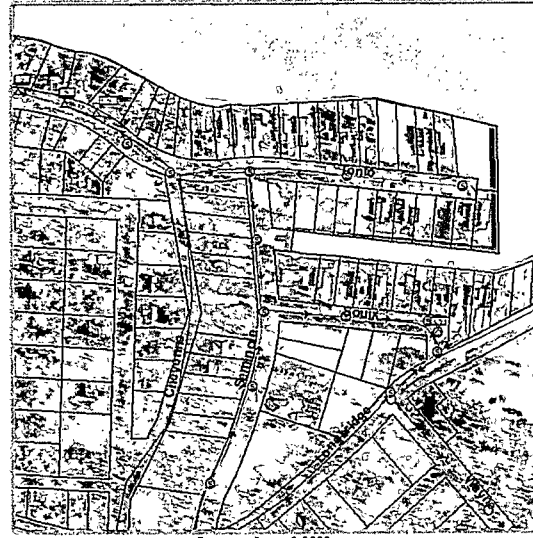

Apache Hills

STATEMENT OF UNDERSTANDING

We understand that the Township's sewer metering has recorded flows approaching or exceeding allowable limits. It is suspected that Infiltration and Inflow (I/I), in the form of non-sanitary "clean water," is entering the system. There are several potential sources of I/I, some of which are more readily identified and cost-effective to investigate than others. Smoke testing is widely recognized as an efficient and economical method for identifying certain types of I/I sources.

We propose conducting smoke testing within the identified collection area(s) to help locate potential points of entry. These may include, but are not limited to, roof drainage connections, damaged or

2960 Lucerne Drive SE
Grand Rapids, MI 49546
P: 616.977.1000
F: 616.977.1005
www.fveng.com

missing sewer lateral cleanout caps, surface drainage inflow, low or compromised manhole rims, and other conditions detectable through this method.

PROJECT APPROACH

Prior to initiating field work, F&V will coordinate with Pentwater Township to notify residents within the testing area(s). This outreach is intended to inform occupants that safe, non-toxic smoke may be visible from plumbing vents, ground surfaces, and potentially within structures if plumbing deficiencies are present.

We recommend that the Township notify local emergency services (fire and police) in advance of the work to prevent unnecessary emergency responses during testing.

At the scheduled time, F&V will provide the necessary personnel and equipment to conduct smoke testing by introducing smoke into selected manholes. During testing, our staff will observe and document locations—both in public areas and on private property—where smoke is observed in unintended locations, indicating potential I/I sources.

Each identified location will be documented with photographs, field notes, and sketches. This information can assist the Township in communicating findings to property owners and facilitating corrective actions.

Following completion of field activities, F&V will prepare a concise report summarizing the findings and providing recommendations. Each identified issue will be categorized (High, Medium, or Low priority) based on our professional assessment of its relative contribution of I/I.

Project Schedule

Smoke testing may be conducted at any convenient time, excluding periods of rainfall. We recommend scheduling during mid-summer when groundwater levels are typically at their lowest, improving the effectiveness of the testing.

Assumptions

Notice to the residents typically takes the form of a one-page notice, often distributed twice, that is handed out or taped to the front door of the home. While F&V will assist in preparing the notice, this proposal assumes the Township will handle distribution.

We also assume the Township will notify local fire and police departments prior to field activities to minimize unnecessary emergency dispatches resulting from resident concerns.

BUDGET

The proposed fee for the scope of services described above is a **lump sum of \$8,800** with an **additional fee of \$1,000** should the Township want to test the Apache Hills section at the same time.

F&V will be prepared to commence work upon receipt of an executed work authorization. Please feel free to contact us with any questions, comments, or requests for additional information regarding this proposal.

Sincerely,

FLEIS & VANDENBRINK

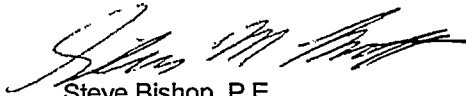

Steve Bishop, P.E.
Project Manager



Don DeVries, P.E.
Principal

WORK AUTHORIZATION

Fleis & VandenBrink Engineering, Inc. (F&V) is hereby authorized to perform Services as detailed in this proposal and authorized under the existing General Consultation Professional Services Agreement with F&V dated March 16, 2023.

Authorized Signer

Date